

DIN41612 Connectors

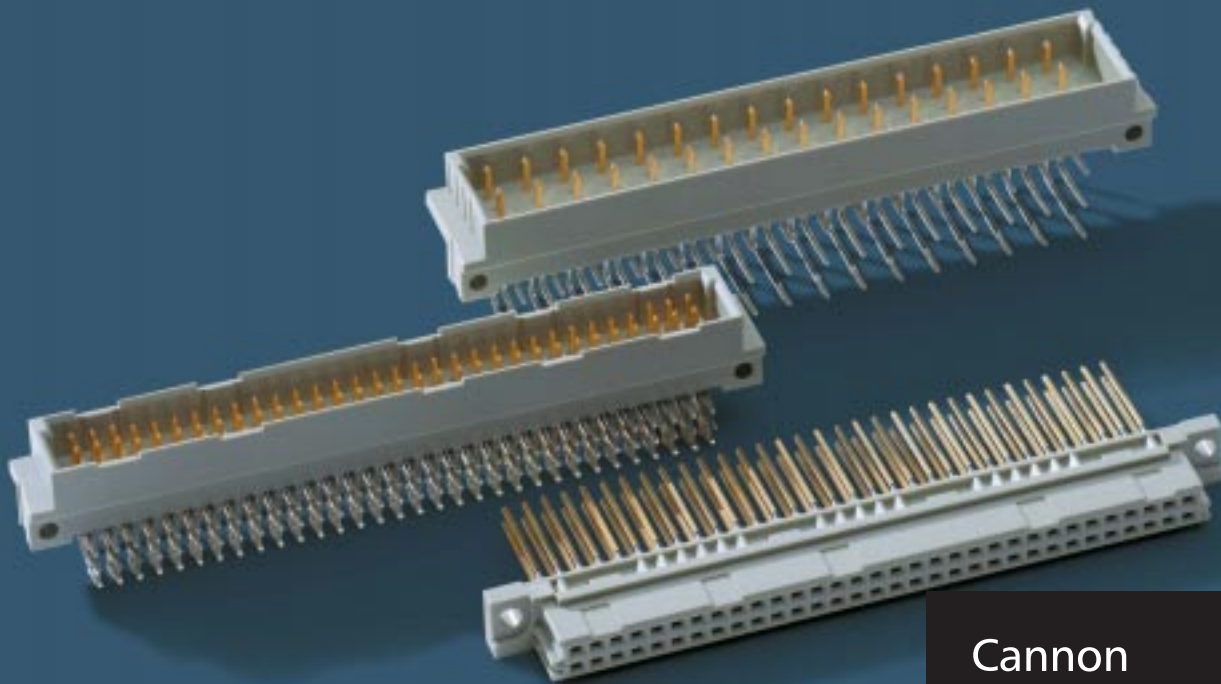

1999

Cannon



ITT Industries
Engineered for life

DIN41612 connectors are used throughout the electronics industry to connect printed circuit boards to one another. Being a long established and widely accepted standard, a very broad range of connector styles and configurations has been developed. Cannon's CDR7 connector family reflects the breadth of options open to the hardware designer.

- ◆ Shell styles B, C, D, E, F, G, H, and R give a varied selection of contact layouts and current carrying capabilities, with either pressfit or solder terminations.
- ◆ Combination layout connectors allow RF and high power inserts to be mixed with standard LF contacts.
- ◆ Extended contact tails are available for wire-wrapping or rear plug-up.
- ◆ First-to-mate and last-to-mate contacts can be loaded to allow the contact mating to be sequenced.
- ◆ E2X cable terminated connectors can be plugged onto the back of C and R style connectors for testing purposes or for board to board connections.
- ◆ If mis-mating connectors is a concern, coding accessories are available which can be installed without sacrificing contacts.

<u>Description</u>	<u>Page</u>
Specification	3
Technical Notes	
PCB Through Hole Dimensions for Pressfit Connectors	4
First-to-Mate or Last-to-Mate Contacts	5
Printed Circuit Boardlocks	5
Coding without Contact Loss	5
CDR7 Connectors	
Shell Style B — Male	6
Shell Style B — Female	7
Shell Style C— Male	8
Shell Style C — Female	9
Shell Style R — Male	11
Shell Style R— Female	12
Shell Style D— Male	13
Shell Style D — Female	14
Shell Style E— Male	15
Shell Style E — Female	16
Shell Style F— Male	17
Shell Style F— Female	18
Shell Style F Low Profile — Female	19
Shell Style G — Male	20
Shell Style G — Female	21
Shell Style H — Male	22
Shell Style H Low Profile — Female	23
Combination Layouts — Male	24
Combination Layouts — Female	25
Power Inserts for Combination Layouts	
High Power Female Inserts - Straight, Solder Terminated	26
High Power Male Inserts - Straight, Solder Terminated	26
High Power Male Inserts - Right Angle, PCB Mount	26
Coaxial Inserts for Combination Layouts	
Coaxial Plugs for Female Connectors	27
Coaxial Jacks for Male Connectors	27
Assembly of Coaxial Cable	27
E2X Cable Connectors	
Introduction	28
Specifications	28
Accessories	29
96 and 64 Way	30
14 and 64 Way	30
45, 30, 21 and 14 Way	31
9 and 6 Way and Coaxial	32
Glossary of Terms	33
Part Number Index	34
Product Safety Information	35

Cannon is a registered trade mark of ITT Industries, Inc.

ITT Industries manufactures the highest quality products available in the marketplace; however these products are intended to be used in accordance with the specifications in this publication. Any use or application that deviates from stated operating specifications is not recommended and may be unsafe. No information and data contained in this publication shall be construed to create any liability on the part of ITT Industries.

Any new issue of this publication shall automatically invalidate and supersede any and all previous issues. **A limited warranty applies to ITT Industries products. Except for obligations assumed by ITT Industries under this warranty, ITT Industries shall not be liable for any loss, damage, cost of repairs, incidental or consequential damages of any kind, whether or not based on express or implied warranty, contract, negligence, or strict liability arising in connection with the design, manufacture, sale, use, or repair of the products.** Product availability, prices and delivery dates are exclusively subject to our respective order confirmation form; the same applies to orders based on development samples delivered. This publication is not to be construed as an offer. It is intended merely as an invitation to make an offer. By this publication, ITT Industries does not assume responsibility or any liability for any patent infringements or other rights of third parties which may result from its use. Reprinting this publication is generally permitted, indicating the source. However, ITT Industries' prior consent must be obtained in all cases.

		B	C	R	Combination
Shell style		6 - 7	8 - 9	11 - 12	24 - 25
See pages					
Contact cavities		2 x 32 = 64, 2 x 16 = 32, 2 x 10 = 20	3 x 32 = 96, 3 x 16 = 48, 3 x 10 = 30	3 x 32 = 96, 3 x 16 = 48	78 + 2, 60 + 4, 42 + 6
Housing material		Glass filled thermoplastic, UL94V-0 rated			
Contact material		Copper alloy			
Plating	Contact area	Au/Ni, DIN Class 2 (400 cycles) is standard. DIN Class 1 & DIN Class 3 on application			
	Terminals	SnPb *	SnPb *	SnPb *	SnPb
	Temperature range	-55°C to +125°C			
Creepage	Contact to earth	1.8mm	1.8mm	1.8mm	1.8mm
	Within row	1.2mm	1.2mm	1.2mm	1.2mm
	Between rows	1.2mm	1.2mm	1.2mm	1.2mm
Air gap	Contact to earth	1.6mm	1.6mm	1.6mm	1.6mm
	Within row	1.2mm	1.2mm	1.2mm	1.2mm
	Between rows	1.2mm	1.2mm	1.2mm	1.2mm
Contact current rating	At 20°C	1.5 A	1.5 A	1.5 A	1.5 A
	At 70°C	1.1 A	1.1 A	1.1 A	1.1 A
	At 100°C	0.7 A	0.7 A	0.7 A	0.7 A
Test voltage, 50 Hz, 1 minute.	Contact to contact	1000 V	1000 V	1000 V	1000 V
	Contact to earth	1550 V	1550 V	1550 V	1550 V
Contact resistance		20 mΩ max	20 mΩ max	20 mΩ max	20 mΩ max
Insulation resistance		5000 MΩ min	5000 MΩ min	5000 MΩ min	5000 MΩ min
Mating force		1 N per contact cavity max			90 N max total

* except where indicated otherwise.

		D	E	F	G	H	H
Shell style		13 - 14	15 - 16	17 - 19	20 - 21	22 - 23	22 - 23
See pages							
Contact cavities		2x16=32	3x16=48	3x16=48	4x16=64	11	15
Housing material		Glass filled thermoplastic, UL94V-0 rated					
Contact material		Copper alloy					
Plating	Contact area	Au/Ni, DIN Class 2 (400 cycles) std. DIN Class 1 & 3 on application				Silver	Silver
	Terminals	SnPb	SnPb	SnPb	SnPb	SnPb	SnPb
	Temperature range	-55°C to +125°C				-65°C to +125°C	
Creepage	Contact to earth	1.8mm	1.8mm	6.0mm	6.0mm	8.0mm	4.5mm
	Within row	3.0mm	3.0mm	3.0mm	3.0mm	8.0mm	4.5mm
	Between rows	3.0mm	3.0mm	3.0mm	3.0mm	8.0mm	4.5mm
Air gap	Contact to earth	1.6mm	1.6mm	3.5mm	3.5mm	4.5mm	4.5mm
	Within row	3.0mm	3.0mm	1.6mm	1.6mm	4.5mm	4.5mm
	Between rows	3.0mm	3.0mm	1.6mm	1.6mm	4.5mm	4.5mm
Contact current rating	At 20°C	5.6 A	5.6 A	5.6 A	5.6 A	15 A	15 A
	At 70°C	4.0 A	4.0 A	4.0 A	4.0 A	11 A	11 A
	At 100°C	2.5 A	2.5 A	2.5 A	2.5 A	8 A	8 A
Test voltage, 50 Hz, 1 minute.	Contact to contact	1550 V	1550 V	1550 V	1550 V	3100 V	3100 V
	Contact to earth	1550 V	1550 V	2500 V	2500 V	3100 V	3100 V
Contact resistance		15 mΩ max	15 mΩ max	15 mΩ max	15 mΩ max	8 mΩ max	8 mΩ max
Insulation resistance		10000 MΩ min	10000 MΩ min	10000 MΩ min	10000 MΩ min	10000 MΩ min	10000 MΩ min
Mating force		40 N max total	60 N max total	75 N max total	100 N max total	80 N max total	90 N max total

PCB Through Hole Dimensions for Pressfit Connectors

Shell styles B and C female connectors are available with special contacts having a smaller pressfit section.

These allow 0.85mm holes and so extra space between the holes for higher density tracking. Consult Cannon Sales Department for details.

GOLD PLATED THROUGH HOLES	Nominal Hole Diameter	Drilled Hole Diameter	Copper (Cu)	Nickel (Ni)	Gold (Au)	Plated Through Hole Diameter
		0.85mm	0.975 - 1.025mm	25µm minimum	2.5µm - 5µm	0.05µm - 0.2µm
	1.0mm	1.125 - 1.175mm	25µm minimum	2.5µm - 5µm	0.05µm - 0.2µm	1.0mm - 1.09mm
	1.6mm	1.725 - 1.775mm	25µm minimum	2.5µm - 5µm	0.05µm - 0.2µm	1.6mm - 1.69mm
TIN PLATED THROUGH HOLES	Nominal Hole Diameter	Drilled Hole Diameter	Copper (Cu)	Tin (Sn)		Plated Through Hole Diameter
	0.85mm	0.975 - 1.025mm	25µm minimum	5µm - 15µm		0.83mm - 0.94mm
	1.0mm	1.125 - 1.175mm	25µm minimum	5µm - 15µm		0.94mm - 1.09mm
	1.6mm	1.725 - 1.775mm	25µm minimum	5µm - 15µm		1.51mm - 1.69mm

First-to-Mate or Last-to-Mate Contacts

For most of the male shell styles, special contacts which can be either longer or shorter than the surrounding contacts, can be loaded into the

cavity. This option also applies to the wire wrap tails of male connectors of shell style R. Consult the Cannon Sales Department for availability,

specifying which cavities should hold either the longer (First-to-Mate) or shorter (Last-to-Mate) contacts.

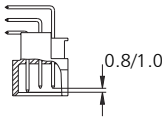
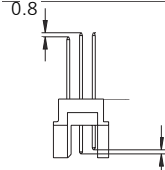
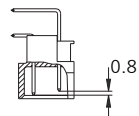
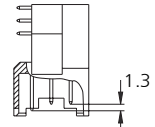
Termination	Shell Style	Standard Contact Length (mm)	First-to-Mate Contact Length (mm)	Last-to-Mate Contact Length (mm)
	B & C male	4.9 ±0.1	+1.0 = 5.9 ±0.1	-0.8 = 4.1 ±0.1
	R male	Terminals	13 ±0.3	+0.8 = 13.8 ±0.3
	R male	Contacts	4.9 ±0.1	+1.0 = 5.9 ±0.1
	D & E male	4.9 ±0.1	+0.8 = 5.7 ±0.1	
	F & G male	6.1 ±0.1	+1.3 = 7.4 ±0.1	

Printed Circuit Boardlocks

CDR7 connectors can be fitted with boardlocks to give additional retaining support to the connector both before and after soldering.

Consult Cannon Sales Department for availability, specifying your PCB thickness.

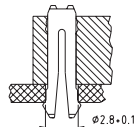
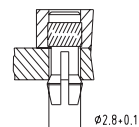
Termination	Shell Style	Boardlock Insertion Force	Boardlock Retention Force	
			Unsoldered	Soldered
Stamped, two prong 	B, C, D, E, F and G male R female	30 N maximum	7.5 N minimum	20 N minimum
Machined, four prong 	B, C, D and E female F low profile female R male	20 N maximum	5 N minimum	25 N minimum

Coding without Contact Loss

To prevent connectors from being mis-mated, shell styles B and C can be coded by inserting plastic keys into the female connector and breaking out sections of the male housing.

Shell styles D, E and F can be coded using holes drilled in the male connector and pins inserted in the female connector.

Consult Cannon Sales Department for details.

Male Connectors

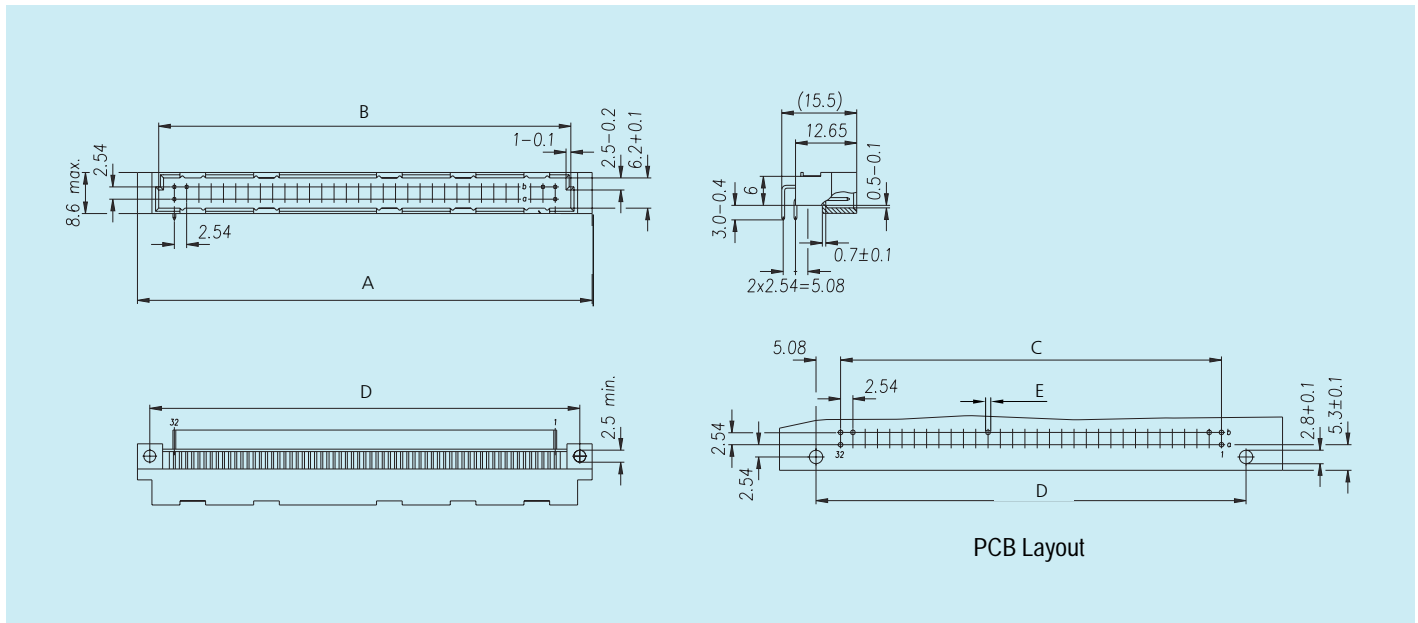

Termination	Terminal	Plating Class	Shell Style	Contact Loading Pattern	Dimensions					Ordering Code
					A	B	C	D	E	
	Pressfit	DIN 2	B1 (2 x 32)	64 way fully loaded	94,0 max	85,2 +0,2	78,74	88,9 ±0,1	1,0 +0,09 -0,06	CDR7B1M64RP1M-DIN2
			B2 (2 x 16)	32 way fully loaded	54,0 max	44,5 +0,2	38,1	48,26 ±0,1	1,0 +0,09 -0,06	CDR7B2M32RP1M-DIN2
			B3 (2 x 10)	20 way fully loaded	39,0 max	29,3 +0,2	22,86	33,02 ±0,1	1,0 +0,09 -0,06	CDR7B3M20RP1M-DIN2
	Solder	DIN 2	B1 (2 x 32)	64 way fully loaded	94,0 max	85,2 +0,2	78,74	88,9 ±0,1	1,0 ±0,1	CDR7B1M64RS2M-DIN2
			B2 (2 x 16)	32 way fully loaded	54,0 max	44,5 +0,2	38,1	48,26 ±0,1	1,0 ±0,1	CDR7B2M32RS2M-DIN2
			B3 (2 x 10)	20 way fully loaded	39,0 max	29,3 +0,2	22,86	33,02 ±0,1	1,0 ±0,1	CDR7B3M20RS2M-DIN2

Pressfit insertion die required.
shell style B1: 884150
shell style B2: 884151
shell style B3: 884152

For class 1 or class 3 contact plating and for alternative loading patterns please consult Cannon Sales Department.

Female Connectors

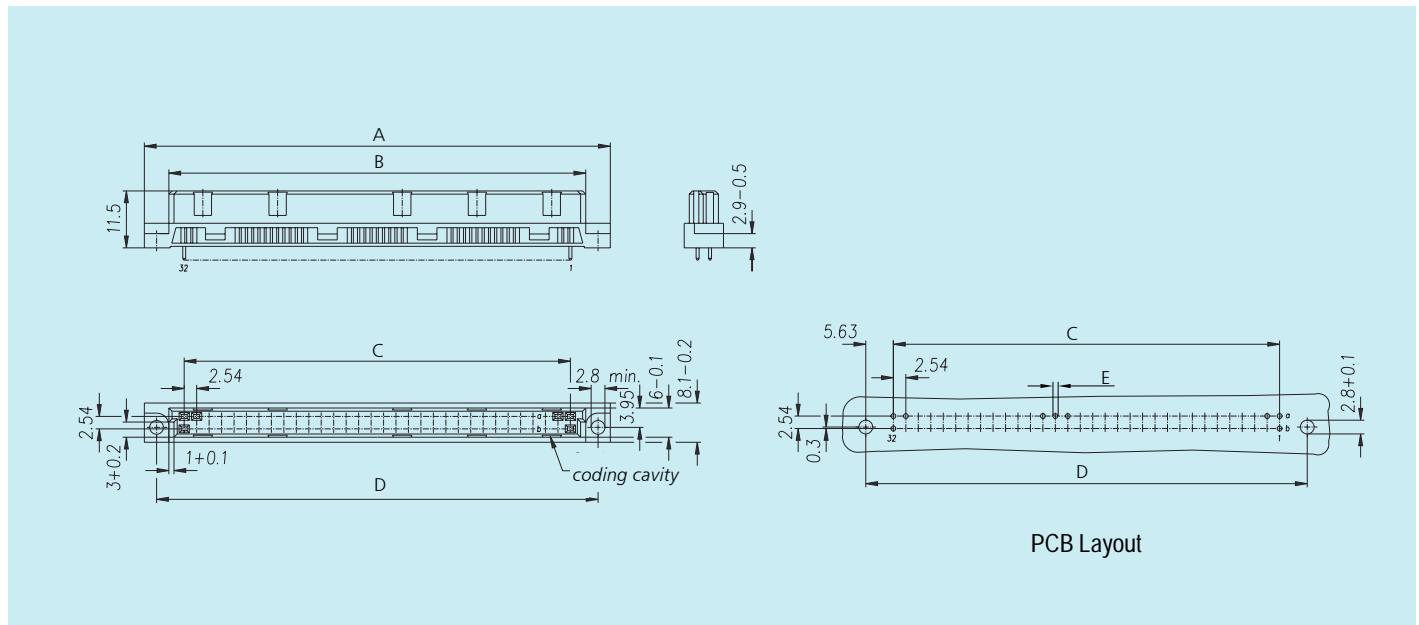

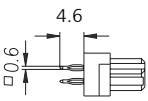
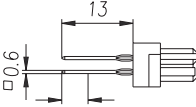
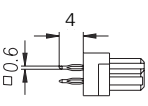
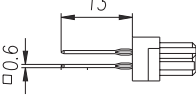
Termination	Terminal	Plating Class	Shell Style	Contact Loading Pattern	Dimensions					Ordering Code
					A	B	C	D	E	
	Pressfit	DIN 2	B1	64 way (2 x 32) fully loaded	95,0 max	85,0 max	78,74	90,0 ±0,1	1,0 +0,09 -0,06	CDR7B1F64TP2M-DIN2
			B2	32 way (2 x 16) fully loaded	55,0 max	44,4 max	38,1	49,36 ±0,1	1,0 +0,09 -0,06	CDR7B2F32TP2M-DIN2
			B3	20 way (2 x 10) fully loaded	39,0 max	29,2 max	22,86	34,0 ±0,1	1,0 +0,09 -0,06	CDR7B3F20TP2M-DIN2
 PLATED Au/Ni	Pressfit	DIN 2	B1	64 way (2 x 32) fully loaded	95,0 max	85,0 max	78,74	90,0 ±0,1	1,0 +0,09 -0,06	CDR7B1F64TP5M-DIN2
			B2	32 way (2 x 16) fully loaded	55,0 max	44,4 max	38,1	49,36 ±0,1	1,0 +0,09 -0,06	CDR7B2F32TP5M-DIN2
			B3	20 way (2 x 10) fully loaded	39,0 max	29,2 max	22,86	34,0 ±0,1	1,0 +0,09 -0,06	CDR7B3F20TP5M-DIN2
	Solder	DIN 2	B1	64 way (2 x 32) fully loaded	95,0 max	85,0 max	78,74	90,0 ±0,1	1,0 ±0,1	CDR7B1F64TS4M-DIN2
			B2	32 way (2 x 16) fully loaded	55,0 max	44,4 max	38,1	49,36 ±0,1	1,0 ±0,1	CDR7B2F32TS4M-DIN2
			B3	20 way (2 x 10) fully loaded	39,0 max	29,2 max	22,86	34,0 ±0,1	1,0 ±0,1	CDR7B3F20TS4M-DIN2
	Solder	DIN 2	B1	64 way (2 x 32) fully loaded	95,0 max	85,0 max	78,74	90,0 ±0,1	1,0 ±0,1	CDR7B1F64TS8M-DIN2
			B2	32 way (2 x 16) fully loaded	55,0 max	44,4 max	38,1	49,36 ±0,1	1,0 ±0,1	CDR7B2F32TS8M-DIN2
			B3	20 way (2 x 10) fully loaded	39,0 max	29,2 max	22,86	34,0 ±0,1	1,0 ±0,1	CDR7B3F20TS8M-DIN2

Pressfit insertion die required.
 shell style B1: 884100
 shell style B2: 884101
 shell style B3: 884102.

For class 1 or class 3 contact plating and for alternative loading patterns please consult Cannon Sales Department.

17mm wirewrap tails also available.

Male Connectors

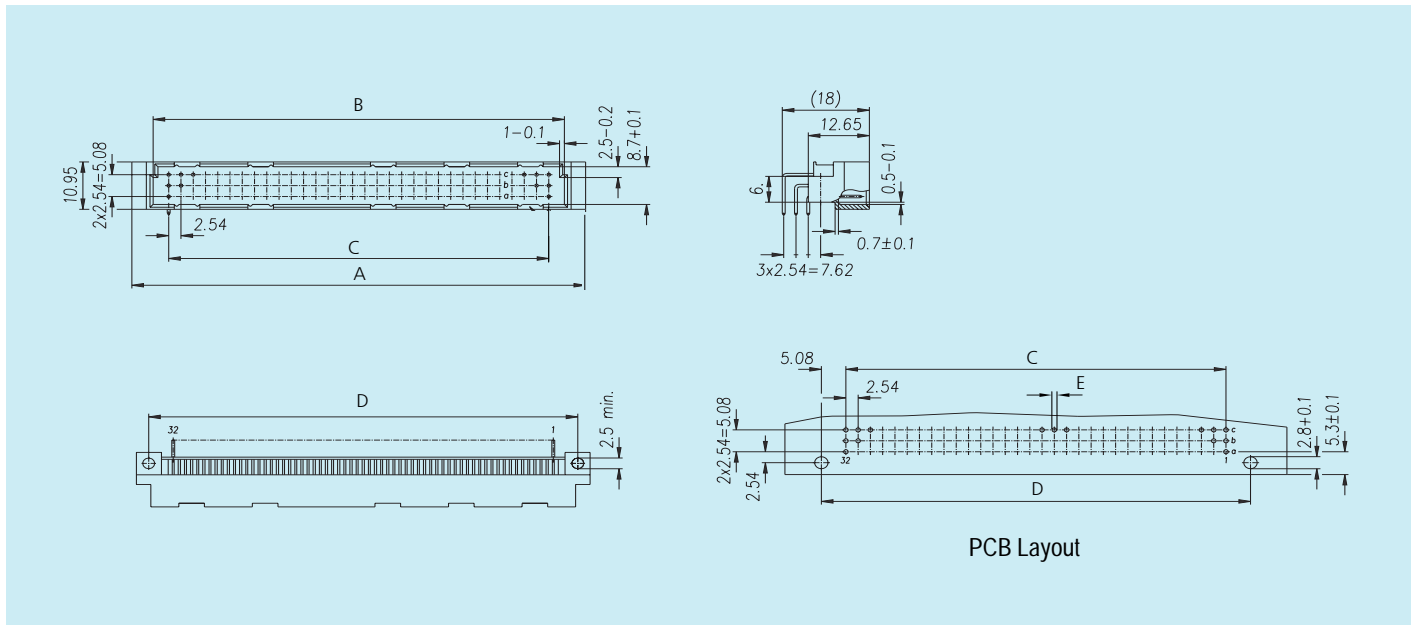

Termination	Terminal	Plating Class	Shell Style	Contact Loading Pattern	Dimensions					Ordering Code
					A	B	C	D	E	
	Pressfit	DIN 2	C1 (3 x 32)	96 way fully loaded	94,0 max	85,2 +0,2	78,74	88,9 ±0,1	1,0 +0,09 -0,06	CDR7C1M96RP1M-DIN2
			C1 (3 x 32)	64 way rows a & c	94,0 max	85,2 +0,2	78,74	88,9 ±0,1	1,0 +0,09 -0,06	CDR7C1M64RP1M-004-DIN2
			C2 (3 x 16)	48 way fully loaded	54,0 max	44,5 +0,2	38,1	48,26 ±0,1	1,0 +0,09 -0,06	CDR7C2M48RP1M-DIN2
			C2 (3 x 16)	32 way rows a & c	54,0 max	44,5 +0,2	38,1	48,26 ±0,1	1,0 +0,09 -0,06	CDR7C2M32RP1M-004-DIN2
			C3 (3 x 10)	30 way fully loaded	39,0 max	29,3 +0,2	22,86	33,02 ±0,1	1,0 +0,09 -0,06	CDR7C3M30RP1M-DIN2
			C1 (3 x 32)	96 way fully loaded	94,0 max	85,2 +0,2	78,74	88,9 ±0,1	1,0 ±0,1	CDR7C1M96RS2M-DIN2
			C1 (3 x 32)	64 way rows a & c	94,0 max	85,2 +0,2	78,74	88,9 ±0,1	1,0 ±0,1	CDR7C1M64RS2M-004-DIN2
			C2 (3 x 16)	48 way fully loaded	54,0 max	44,5 +0,2	38,1	48,26 ±0,1	1,0 ±0,1	CDR7C2M48RS2M-DIN2
			C2 (3 x 16)	32 way rows a & c	54,0 max	44,5 +0,2	38,1	48,26 ±0,1	1,0 ±0,1	CDR7C2M32RS2M-004-DIN2
			C3 (3 x 10)	30 way fully loaded	39,0 max	29,3 +0,2	22,86	33,02 ±0,1	1,0 ±0,1	CDR7C3M30RS2M-DIN2

Pressfit insertion die required.

shell style C1: 884250

shell style C2: 884251

shell style C3: 884252

For class 1 or class 3 contact plating and for alternative loading patterns please consult Cannon Sales Department.

Female Connectors

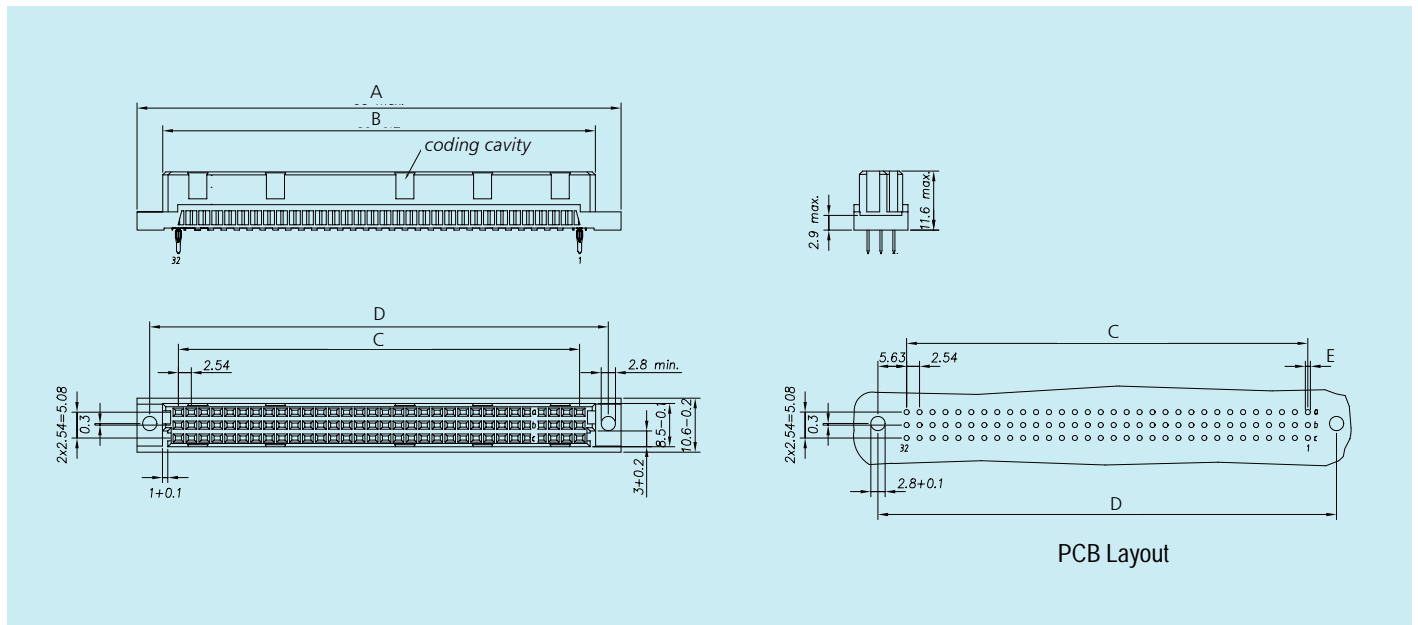

Termination	Terminal	Plating Class	Shell Style	Contact Loading Pattern	Dimensions					Ordering Code
					A	B	C	D	E	
	Pressfit	DIN 2	C1 (3 x 32)	96 way fully loaded	95,0 max	85,0 max	78,74	90,0 ±0,1	1,0 +0,09 -0,06	CDR7C1F96TP2M-DIN2
			C1 (3 x 32)	64 way rows a & c	95,0 max	85,0 max	78,74	90,0 ±0,1	1,0 +0,09 -0,06	CDR7C1F64TP2M-004-DIN2
			C2 (3 x 16)	48 way fully loaded	55,0 max	44,4 max	38,1	49,36 ±0,1	1,0 +0,09 -0,06	CDR7C2F48TP2M-DIN2
			C2 (3 x 16)	32 way rows a & c	55,0 max	44,4 max	38,1	49,36 ±0,1	1,0 +0,09 -0,06	CDR7C2F32TP2M-004-DIN2
			C3 (3 x 10)	30 way fully loaded	39,0 max	29,2 max	22,86	34,0 ±0,1	1,0 +0,09 -0,06	CDR7C3F30TP2M-DIN2
			C1 (3 x 32)	96 way fully loaded	95,0 max	85,0 max	78,74	90,0 ±0,1	1,0 +0,09 -0,06	CDR7C1F96TP5M-DIN2
	Pressfit	DIN 2	C1 (3 x 32)	96 way fully loaded	95,0 max	85,0 max	78,74	90,0 ±0,1	1,0 +0,09 -0,06	CDR7C1F64TP5M-004-DIN2
			C1 (3 x 32)	64 way rows a & c	95,0 max	85,0 max	78,74	90,0 ±0,1	1,0 +0,09 -0,06	CDR7C1F64TP5M-004-DIN2
			C2 (3 x 16)	48 way fully loaded	55,0 max	44,4 max	38,1	49,36 ±0,1	1,0 +0,09 -0,06	CDR7C2F48TP5M-DIN2
			C2 (3 x 16)	32 way rows a & c	55,0 max	44,4 max	38,1	49,36 ±0,1	1,0 +0,09 -0,06	CDR7C2F32TP5M-004-DIN2
			C3 (3 x 10)	30 way fully loaded	39,0 max	29,2 max	22,86	34,0 ±0,1	1,0 +0,09 -0,06	CDR7C3F30TP5M-DIN2
			C1 (3 x 32)	96 way fully loaded	95,0 max	85,0 max	78,74	90,0 ±0,1	1,0 +0,09 -0,06	CDR7C1F96TP5M-DIN2

Pressfit insertion die required.
all shell styles: 886900

(Continued on next page)

Female Connectors (continued)

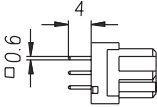
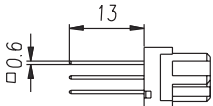
Termination	Terminal	Plating Class	Shell Style	Contact Loading Pattern	Dimensions					Ordering Code
					A	B	C	D	E	
	Solder	DIN 2	C1 (3 x 32)	96 way fully loaded	95,0 max	85,0 max	78,74	90,0 ±0,1	1,0 ±0,1	CDR7C1F96TS4M-DIN2
			C1 (3 x 32)	64 way rows a & c	95,0 max	85,0 max	78,74	90,0 ±0,1	1,0 ±0,1	CDR7C1F64TS4M-004-DIN2
			C2 (3 x 16)	48 way fully loaded	55,0 max	44,4 max	38,1	49,36 ±0,1	1,0 ±0,1	CDR7C2F48TS4M-DIN2
			C2 (3 x 16)	32 way rows a & c	55,0 max	44,4 max	38,1	49,36 ±0,1	1,0 ±0,1	CDR7C2F32TS4M-004-DIN2
			C3 (3 x 10)	30 way fully loaded	39,0 max	29,2 max	22,86	34,0 ±0,1	1,0 ±0,1	CDR7C3F30TS4M-DIN2
			C1 (3 x 32)	96 way fully loaded	95,0 max	85,0 max	78,74	90,0 ±0,1	1,0 ±0,1	CDR7C1F96TS8M-DIN2
			C1 (3 x 32)	64 way rows a & c	95,0 max	85,0 max	78,74	90,0 ±0,1	1,0 ±0,1	CDR7C1F64TS8M-004-DIN2
			C2 (3 x 16)	48 way fully loaded	55,0 max	44,4 max	38,1	49,36 ±0,1	1,0 ±0,1	CDR7C2F48TS8M-DIN2
			C2 (3 x 16)	32 way rows a & c	55,0 max	44,4 max	38,1	49,36 ±0,1	1,0 ±0,1	CDR7C2F32TS8M-004-DIN2
			C3 (3 x 10)	30 way fully loaded	39,0 max	29,2 max	22,86	34,0 ±0,1	1,0 ±0,1	CDR7C3F30TS8M-DIN2
	Solder	DIN 2	C1 (3 x 32)	96 way fully loaded	95,0 max	85,0 max	78,74	90,0 ±0,1	1,0 ±0,1	CDR7C1F96TS8M-DIN2
			C1 (3 x 32)	64 way rows a & c	95,0 max	85,0 max	78,74	90,0 ±0,1	1,0 ±0,1	CDR7C1F64TS8M-004-DIN2
			C2 (3 x 16)	48 way fully loaded	55,0 max	44,4 max	38,1	49,36 ±0,1	1,0 ±0,1	CDR7C2F48TS8M-DIN2
			C2 (3 x 16)	32 way rows a & c	55,0 max	44,4 max	38,1	49,36 ±0,1	1,0 ±0,1	CDR7C2F32TS8M-004-DIN2
			C3 (3 x 10)	30 way fully loaded	39,0 max	29,2 max	22,86	34,0 ±0,1	1,0 ±0,1	CDR7C3F30TS8M-DIN2

For class 1 or class 3 contact plating and for alternative loading patterns please consult Cannon Sales Department.

17mm wirewrap tails also available.

Male Connectors

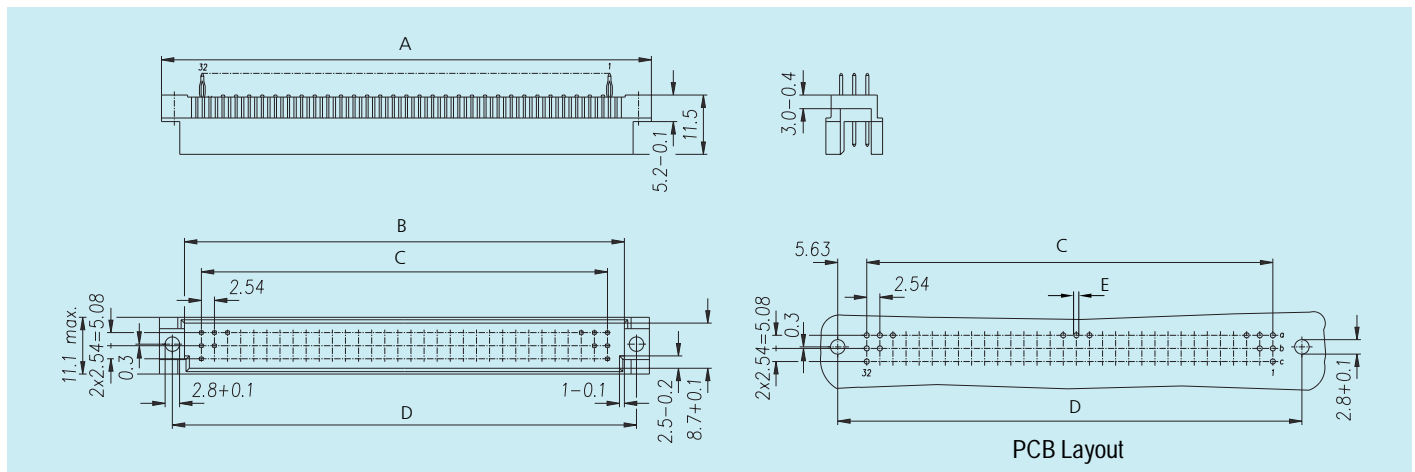

Termination	Terminal	Plating Class	Shell Style	Contact Loading Pattern	Dimensions					Ordering Code
					A	B	C	D	E	
	Pressfit	DIN 2	R1	96 way (3 x 32) fully loaded	95,0 max	85,2 +0,2	78,74	90 ±0,1	1,0 +0,09 -0,06	CDR7R1M96TP2M-DIN2
			R1	64 way (3 x 32) rows a & c	95,0 max	85,2 +0,2	78,74	90 ±0,1	1,0 +0,09 -0,06	CDR7R1M64TP2M-004-DIN2
			R2	48 way (3 x 16) fully loaded	55,0 max	44,56 +0,2	38,1	50 ±0,1	1,0 +0,09 -0,06	CDR7R2M48TP2M-DIN2
			R2	32 way (3 x 16) rows a & c	55,0 max	44,56 +0,2	38,1	50 ±0,1	1,0 +0,09 -0,06	CDR7R2M32TP2M-004-DIN2
			R1	96 way (3 x 32) fully loaded	95,0 max	85,2 +0,2	78,74	90 ±0,1	1,0 +0,09 -0,06	CDR7R1M96TP5M-DIN2
			R1	64 way (3 x 32) rows a & c	95,0 max	85,2 +0,2	78,74	90 ±0,1	1,0 +0,09 -0,06	CDR7R1M64TP5M-004-DIN2
			R2	48 way (3 x 16) fully loaded	55,0 max	44,56 +0,2	38,1	50 ±0,1	1,0 +0,09 -0,06	CDR7R2M48TP5M-DIN2
			R2	32 way (3 x 16) rows a & c	55,0 max	44,56 +0,2	38,1	50 ±0,1	1,0 +0,09 -0,06	CDR7R2M32TP5M-004-DIN2
	Solder	DIN2	R1	96 way (3 x 32) fully loaded	95,0 max	85,2 +0,2	78,74	90 ±0,1	1,0 ±0,1	CDR7R1M96TS4M-DIN2
			R1	64 way (3 x 32) rows a & c	95,0 max	85,2 +0,2	78,74	90 ±0,1	1,0 ±0,1	CDR7R1M64TS4M-004-DIN2
			R2	48 way (3 x 16) fully loaded	55,0 max	44,56 +0,2	38,1	50 ±0,1	1,0 ±0,1	CDR7R2M48TS4M-DIN2
			R2	32 way (3 x 16) rows a & c	55,0 max	44,56 +0,2	38,1	50 ±0,1	1,0 ±0,1	CDR7R2M32TS4M-004-DIN2
			R1	96 way (3 x 32) fully loaded	95,0 max	85,2 +0,2	78,74	90 ±0,1	1,0 ±0,1	CDR7R1M96TS8M-DIN2
			R1	64 way (3 x 32) rows a & c	95,0 max	85,2 +0,2	78,74	90 ±0,1	1,0 ±0,1	CDR7R1M64TS8M-004-DIN2
			R2	48 way (3 x 16) fully loaded	55,0 max	44,56 +0,2	38,1	50 ±0,1	1,0 ±0,1	CDR7R2M48TS8M-DIN2
			R2	32 way (3 x 16) rows a & c	55,0 max	44,56 +0,2	38,1	50 ±0,1	1,0 ±0,1	CDR7R2M32TS8M-004-DIN2

Pressfit insertion die required.
 shell style R1: 884525
 shell style R2: 884526

For class 1 or class 3 contact plating and for alternative loading patterns please consult Cannon Sales Department.

17mm wirewrap tails also available.

Female Connectors

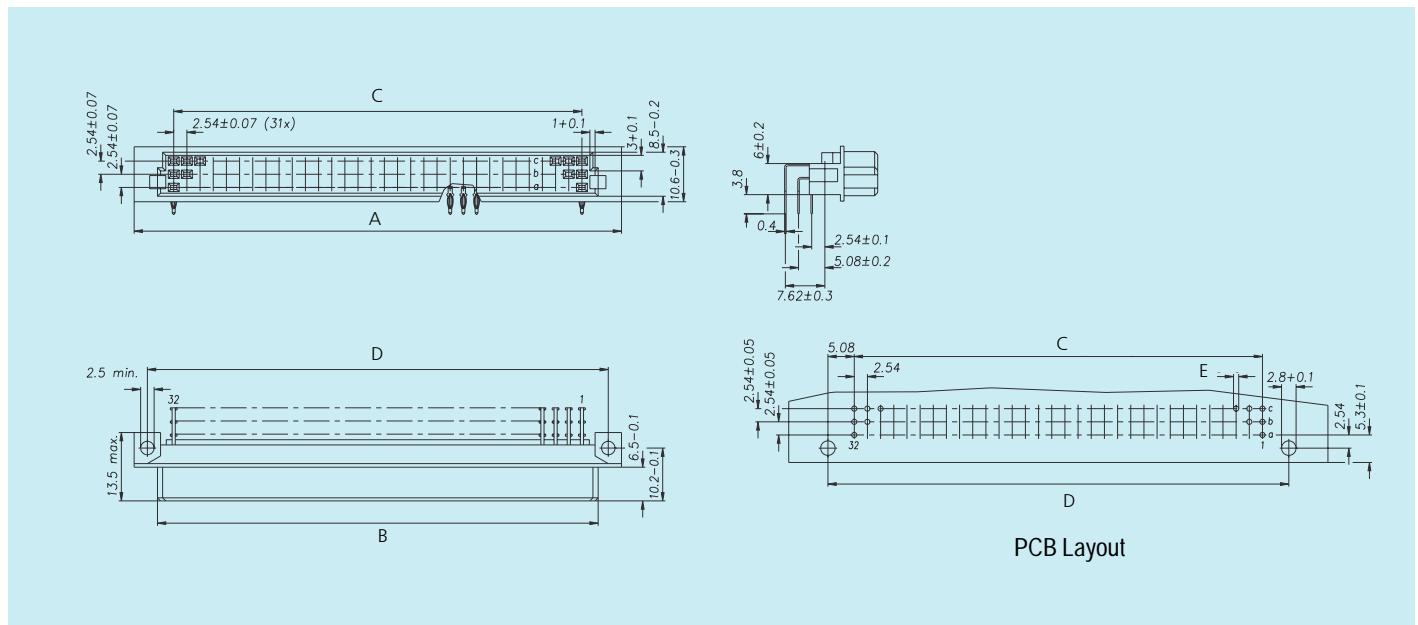

Termination	Terminal	Plating Class	Shell Style	Contact Loading Pattern	Dimensions					Ordering Code
					A	B	C	D	E	
	Pressfit	DIN 2	R1	96 way (3 x 32) fully loaded	94,0 ±0,2	85,0 -0,2	78,74	88,9 ±0,1	1,0 +0,09 -0,06	CDR7R1F96RP1M-DIN2
			R1	64 way (3 x 32) rows a & c	94,0 ±0,2	85,0 -0,2	78,74	88,9 ±0,1	1,0 +0,09 -0,06	CDR7R1F64RP1M-004-DIN2
			R2	48 way (3 x 16) fully loaded	53,36 -0,2	44,4 -0,2	38,1	48,26 ±0,1	1,0 +0,09 -0,06	CDR7R2F48RP1M-DIN2
			R2	32 way (3 x 16) rows a & c	53,36 -0,2	44,4 -0,2	38,1	48,26 ±0,1	1,0 +0,09 -0,06	CDR7R2F32RP1M-004-DIN2
	Solder	DIN 2	R1	96 way (3 x 32) fully loaded	94,0 ±0,2	85,0 -0,2	78,74	88,9 ±0,1	1,0 ±0,1	CDR7R1F96RS2M-DIN2
			R1	64 way (3 x 32) rows a & c	94,0 ±0,2	85,0 -0,2	78,74	88,9 ±0,1	1,0 ±0,1	CDR7R1F64RS2M-004-DIN2
			R2	48 way (3 x 16) fully loaded	53,36 -0,2	44,4 -0,2	38,1	48,26 ±0,1	1,0 ±0,1	CDR7R2F48RS2M-DIN2
			R2	32 way (3 x 16) rows a & c	53,36 -0,2	44,4 -0,2	38,1	48,26 ±0,1	1,0 ±0,1	CDR7R2F32RS2M-004-DIN2

Pressfit insertion die required.
shell style R1: 884500
shell style R2: 884501

For class 1 or class 3 contact plating and for alternative loading patterns please consult Cannon Sales Department.

Male Connectors

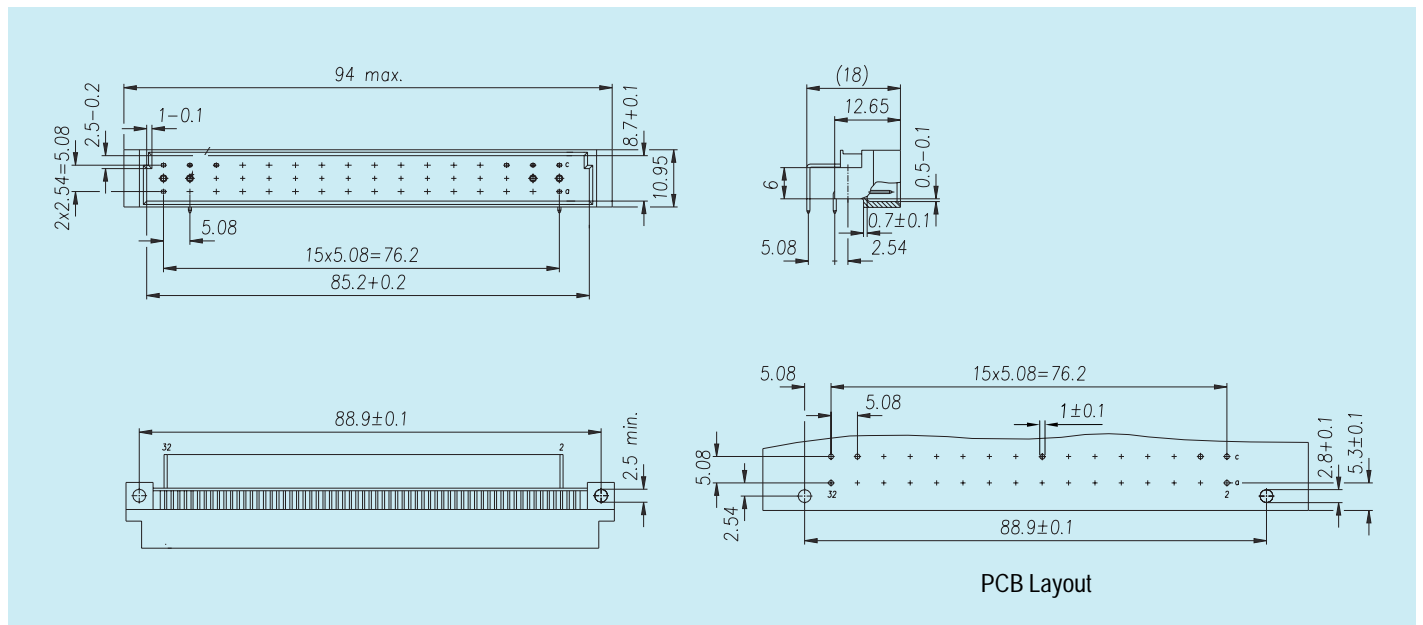

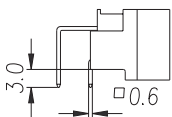
Termination	Terminal Class	Plating Class	Shell Style	Contact Loading Pattern	Ordering Code
	Solder	DIN 2	D1 (2 x 16)	32 way fully loaded	CDR7D1M32RS2M-DIN2

For class 1 or class 3 contact plating and for alternative loading patterns please consult Cannon Sales Department.

Female Connectors

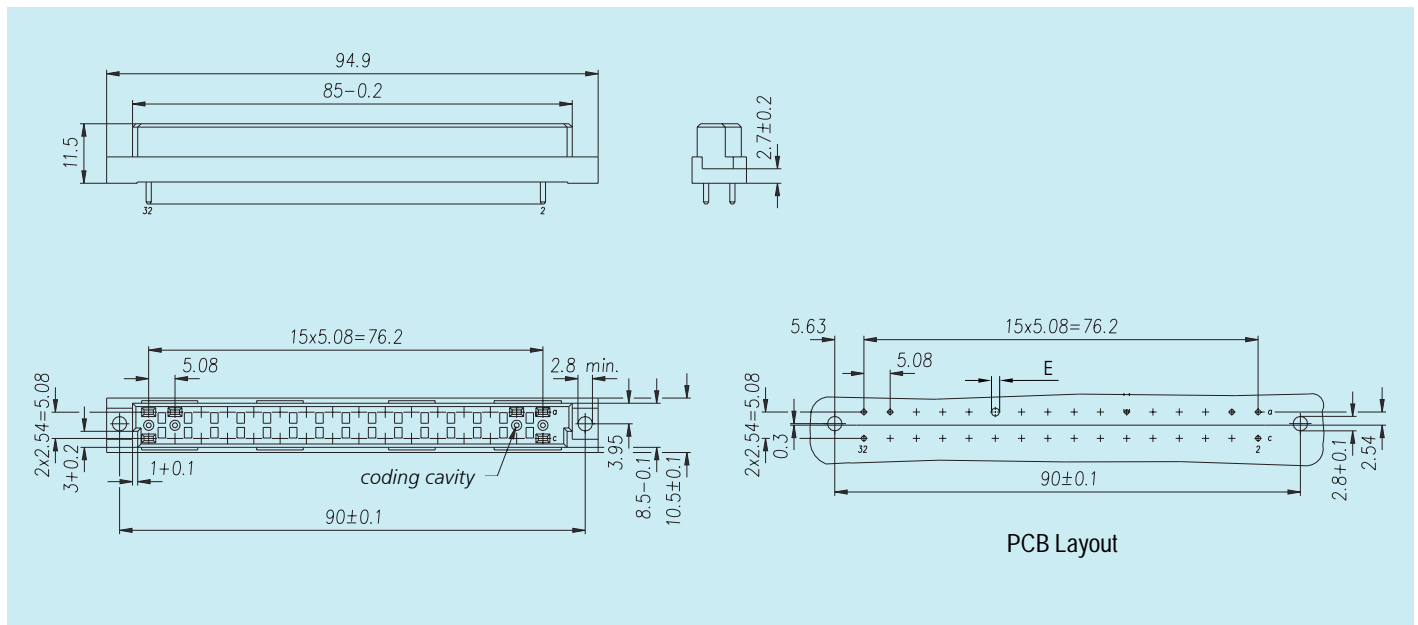

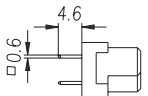
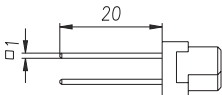
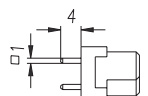
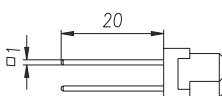
Termination	Terminal	Plating Class	Shell Style	Contact Loading Pattern	Dimension E	Ordering Code
	Pressfit	DIN 2	D1 (2 x 16)	32 way fully loaded	1,0 +0,09 -0,06	CDR7D1F32TP2M-DIN2
	Pressfit	DIN 2	D1 (2 x 16)	32 way fully loaded	1,6 ±0,09	CDR7D1F32TP8M-DIN2
	Solder	DIN 2	D1 (2 x 16)	32 way fully loaded	1,6 ±0,1	CDR7D1F32TS5M-DIN2
	Solder	DIN 2	D1 (2 x 16)	32 way fully loaded	1,6 ±0,1	CDR7D1F32TS9M-DIN2

Pressfit insertion die required: 884303

For class 1 or class 3 contact plating and for alternative loading patterns please consult Cannon Sales Department.

Male Connectors

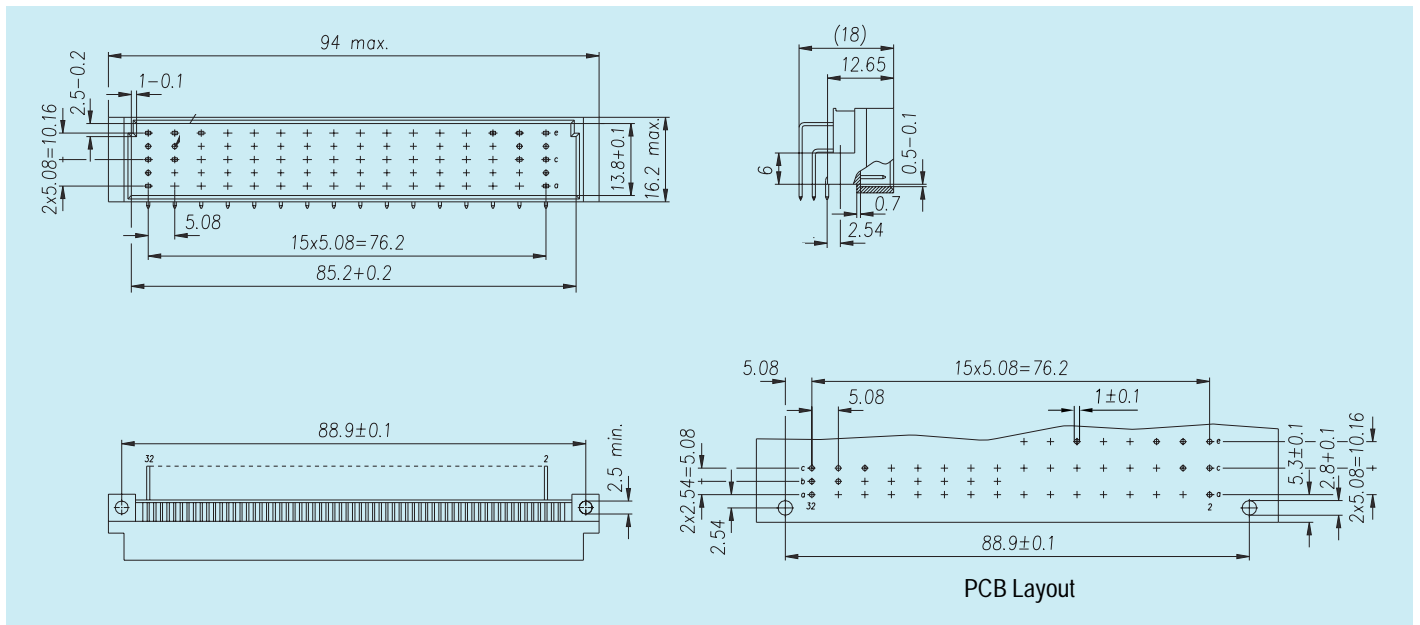

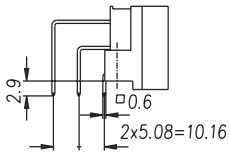
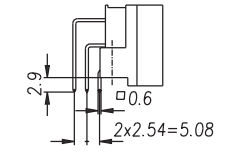
Termination	Terminal	Plating Class	Shell Style	Contact Loading Pattern	Ordering Code
	Solder	DIN 2	E1 (3 x 16)	48 way fully loaded	CDR7E1M48RS1M-DIN2
	Solder	DIN 2	E2 (3 x 16)	48 way fully loaded	CDR7E2M48RS1M-DIN2

For class 1 or class 3 contact plating and for alternative loading patterns please consult Cannon Sales Department.

Female Connectors

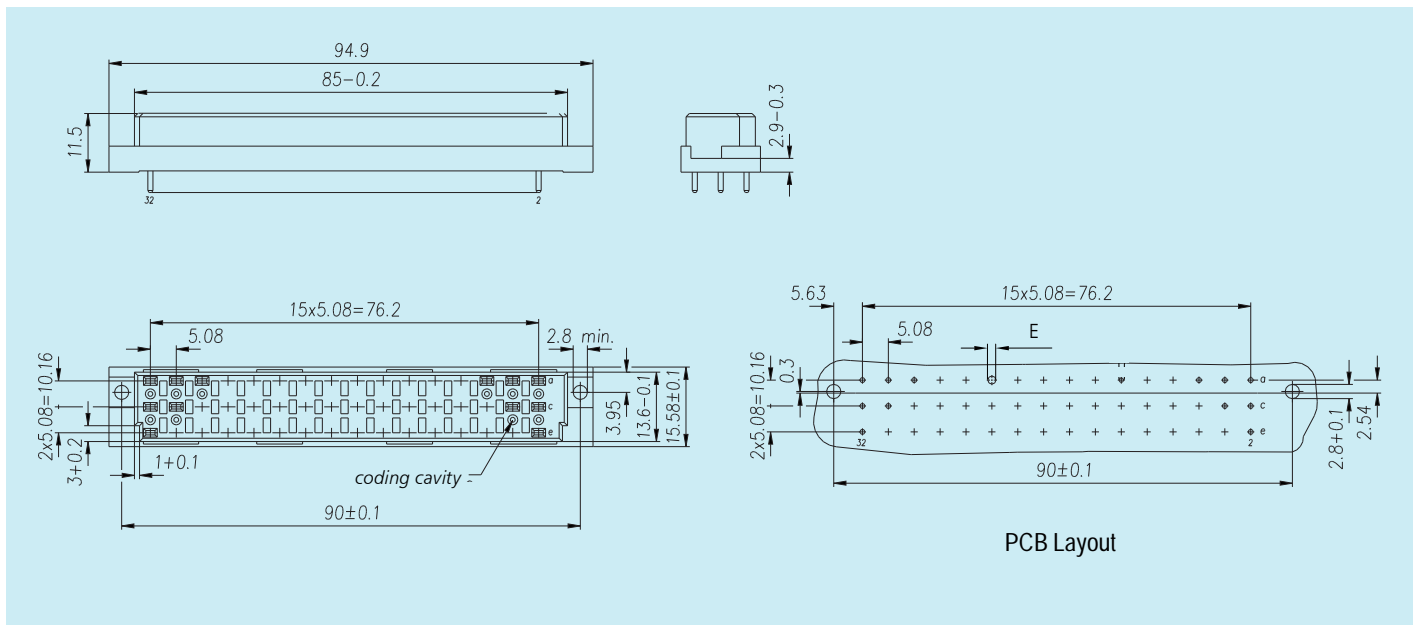

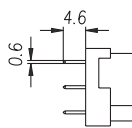
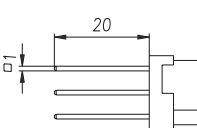
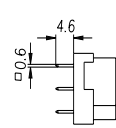
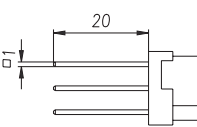
Termination	Terminal	Plating Class	Shell Style	Contact Loading Pattern	Dimension E	Ordering Code
	Pressfit	DIN 2	E1 (3 x 16)	48 way fully loaded	1,0 +0,09 -0,06	CDR7E1F48TP2M-DIN2
	Pressfit	DIN 2	E1 (3 x 16)	48 way fully loaded	1,6 ±0,09	CDR7E1F48TP8M-DIN2
	Solder	DIN 2	E1 (3 x 16)	48 way fully loaded	1,0 ±0,1	CDR7E1F48TS5M-DIN2
	Solder	DIN 2	E1 (3 x 16)	48 way fully loaded	1,6 ±0,1	CDR7E1F48TS9M-DIN2

Pressfit insertion die required: 884353

For class 1 or class 3 contact plating and for alternative loading patterns please consult Cannon Sales Department.

Male Connectors

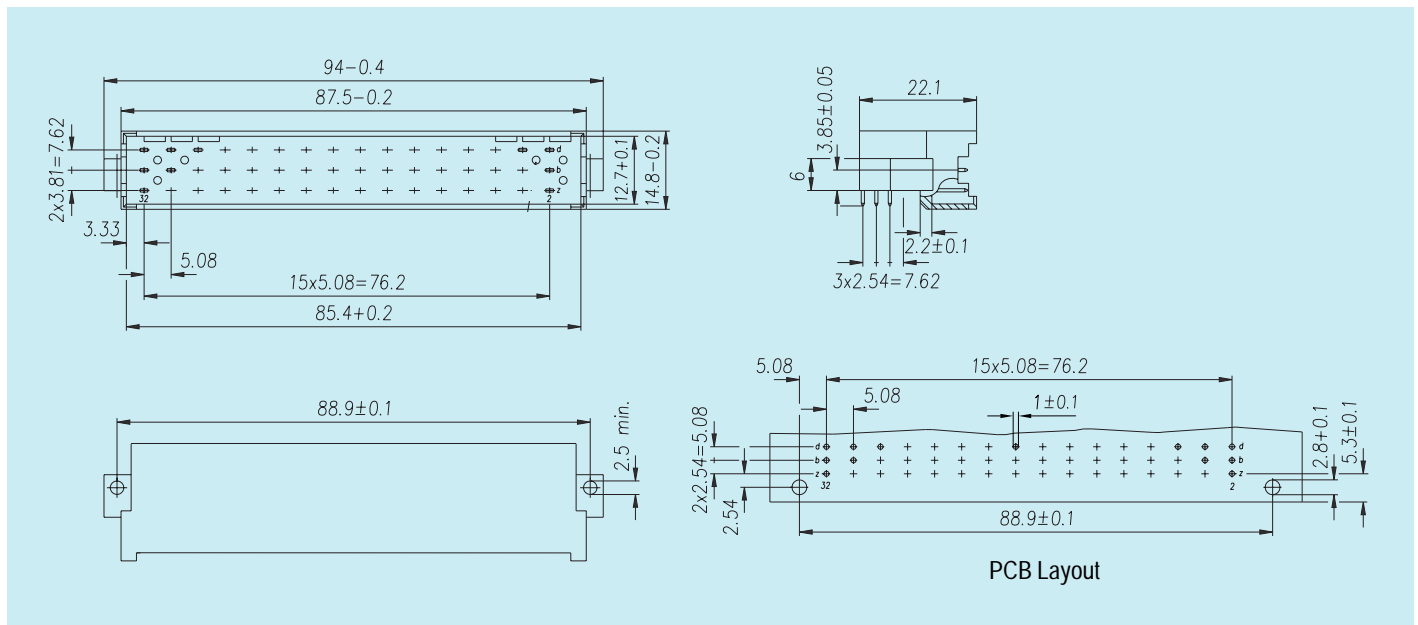

Termination	Terminal	Plating Class	Shell Style	Contact Loading Pattern	Ordering Code
	Solder	DIN 2	F1 (3 x 16)	48 way fully loaded	CDR7F1M48RS2M-DIN2

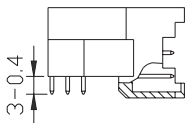

For class 1 or class 3 contact plating and for alternative loading patterns please consult Cannon Sales Department.

Female Connectors

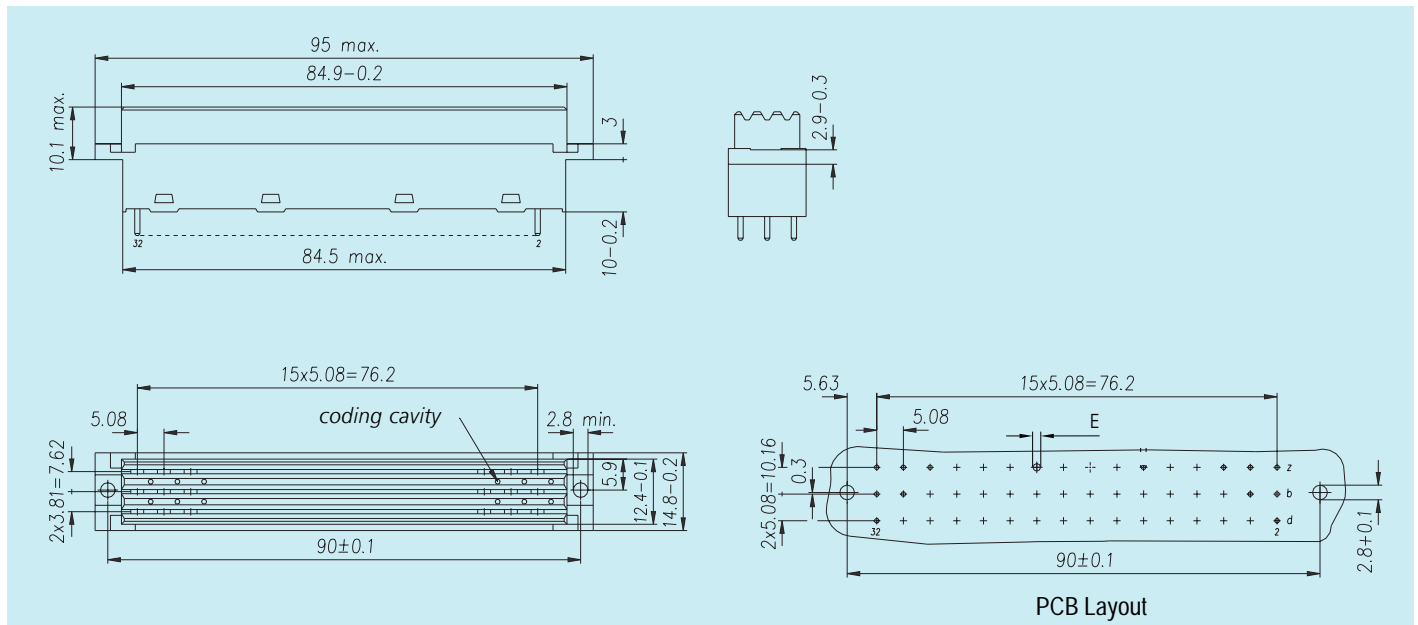

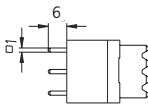
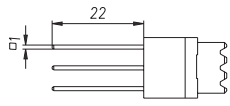
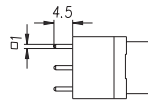
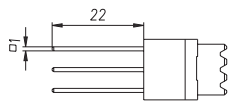
Termination	Terminal	Plating Class	Shell Style	Contact Loading Pattern	Dimension E	Ordering Code
	Pressfit	DIN 2	F1 (3 x 16)	48 way fully loaded	1,6 ±0,09	CDR7F1F48TP2M-DIN2
	Pressfit	DIN 2	F1 (3 x 16)	48 way fully loaded	1,6 ±0,09	CDR7F1F48TP8M-DIN2
	Solder	DIN 2	F1 (3 x 16)	48 way fully loaded	1,6 ±0,1	CDR7F1F48TS5M-DIN2
	Solder	DIN 2	F1 (3 x 16)	48 way fully loaded	1,6 ±0,1	CDR7F1F48TS9M-DIN2

Pressfit insertion die required: 884401

For class 1 or class 3 contact plating and for alternative loading patterns please consult Cannon Sales Department.

Female Connectors

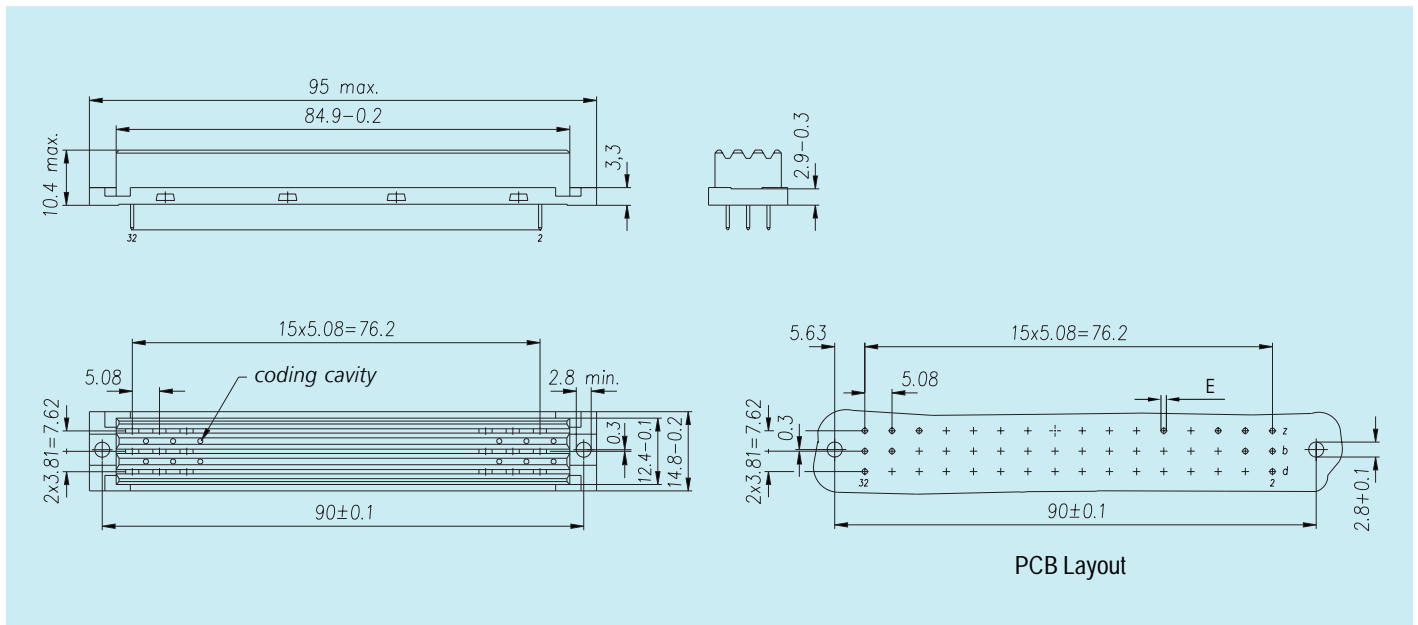

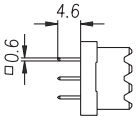
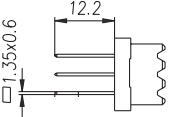
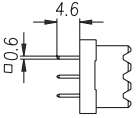
Termination	Terminal	Plating Class	Shell Style	Contact Loading Pattern	Dimension E	Ordering Code
	Pressfit	DIN 2	F2 (3 x 16)	48 way fully loaded	1,0 +0,09 -0,06	CDR7F2F48TP2M-DIN2
	Pressfit	DIN 2	F2 (3 x 16)	48 way fully loaded	1,6 ±0,09	CDR7F2F48TP5M-DIN2
	Solder	DIN 2	F2 (3 x 16)	48 way fully loaded	1,0 ±0,1	CDR7F2F48TS5M-DIN2

Pressfit insertion die required: 884406

For class 1 or class 3 contact plating and for alternative loading patterns please consult Cannon Sales Department.

Male Connectors

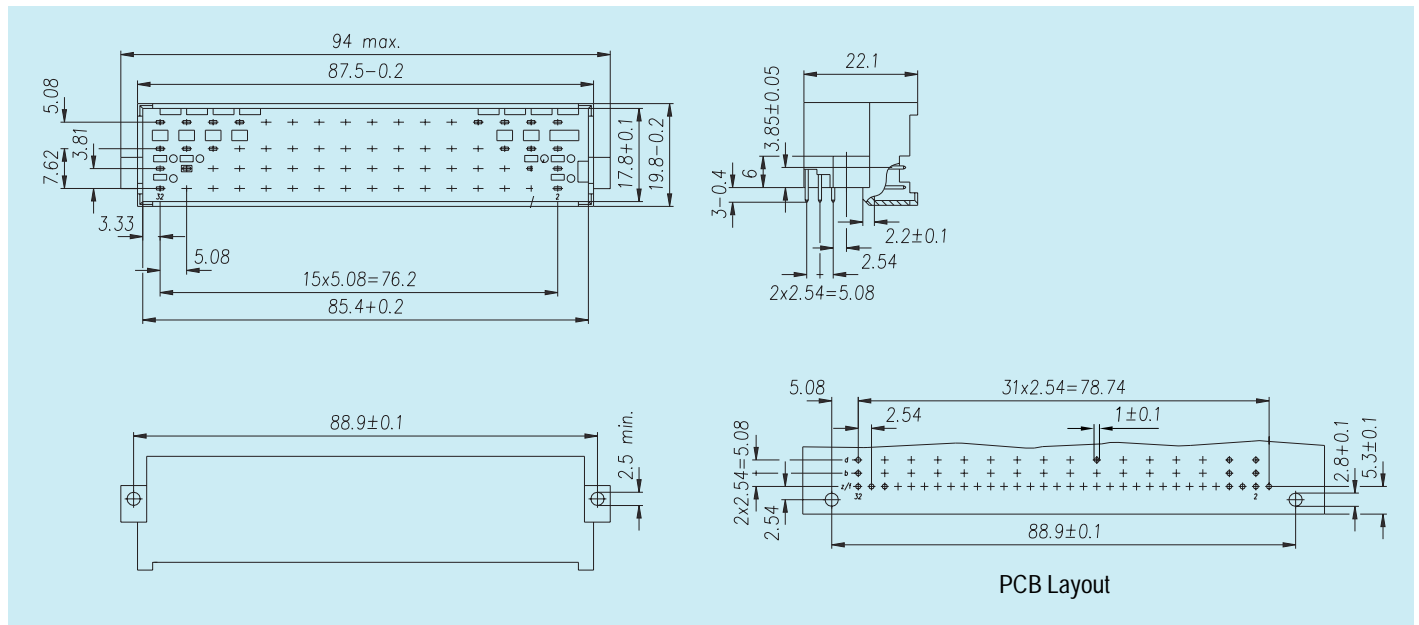

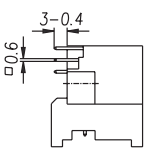
Termination	Terminal	Plating Class	Shell Style	Contact Loading Pattern	Ordering Code
	Solder	DIN 2	G1 (4 x 16)	64 way fully loaded	CDR7G1M64RS2M-DIN2

For class 1 or class 3 contact plating and for alternative loading patterns please consult Cannon Sales Department.

Female Connectors

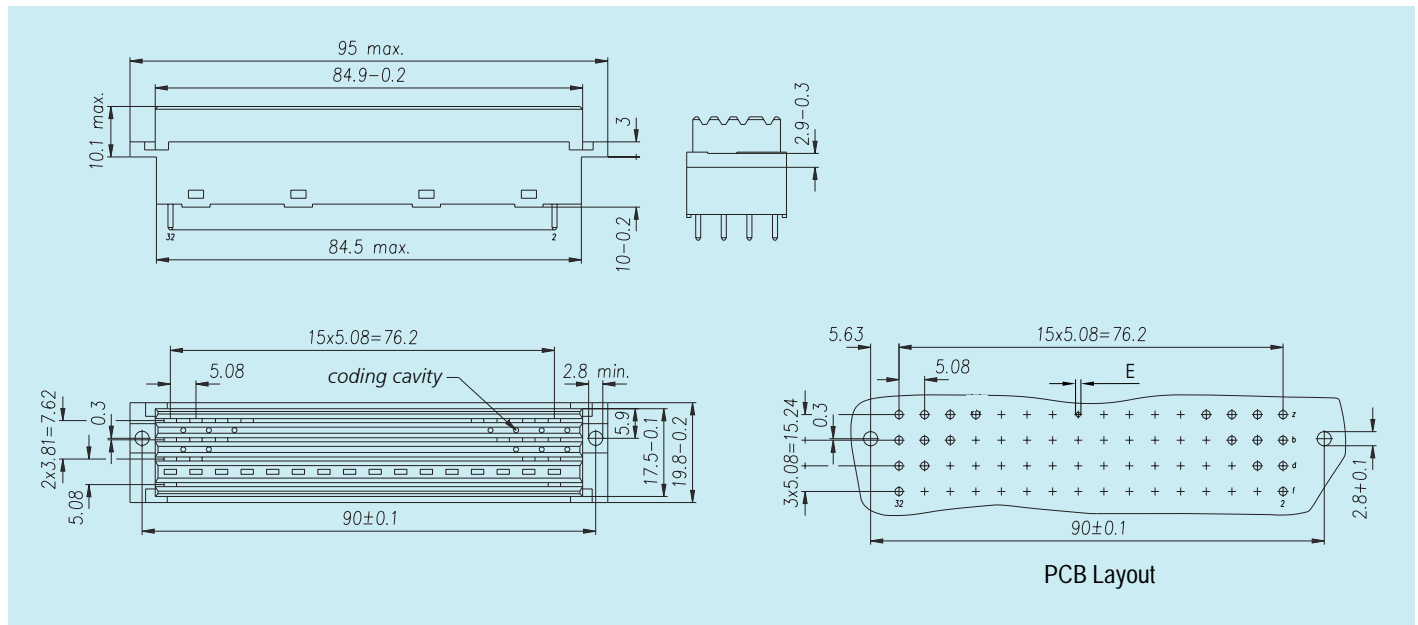

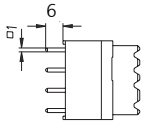
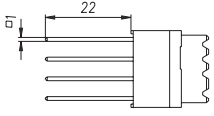
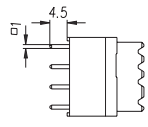
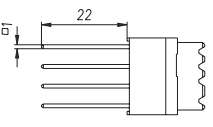
Termination	Terminal	Plating Class	Shell Style	Contact Loading Pattern	Dimension E	Ordering Code
	Pressfit	DIN 2	G1 (4 x 16)	64 way fully loaded	1,6 ±0,09	CDR7G1F64TP2M-DIN2
	Pressfit	DIN 2	G1 (4 x 16)	64 way fully loaded	1,6 ±0,09	CDR7G1F64TP8M-DIN2
	Solder	DIN 2	G1 (4 x 16)	64 way fully loaded	1,6 ±0,1	CDR7G1F64TS5M-DIN2
	Solder	DIN 2	G1 (4 x 16)	64 way fully loaded	1,6 ±0,1	CDR7G1F64TS9M-DIN2

Pressfit insertion die required: 884453

For class 1 or class 3 contact plating and for alternative loading patterns please consult Cannon Sales Department.

Male Connectors

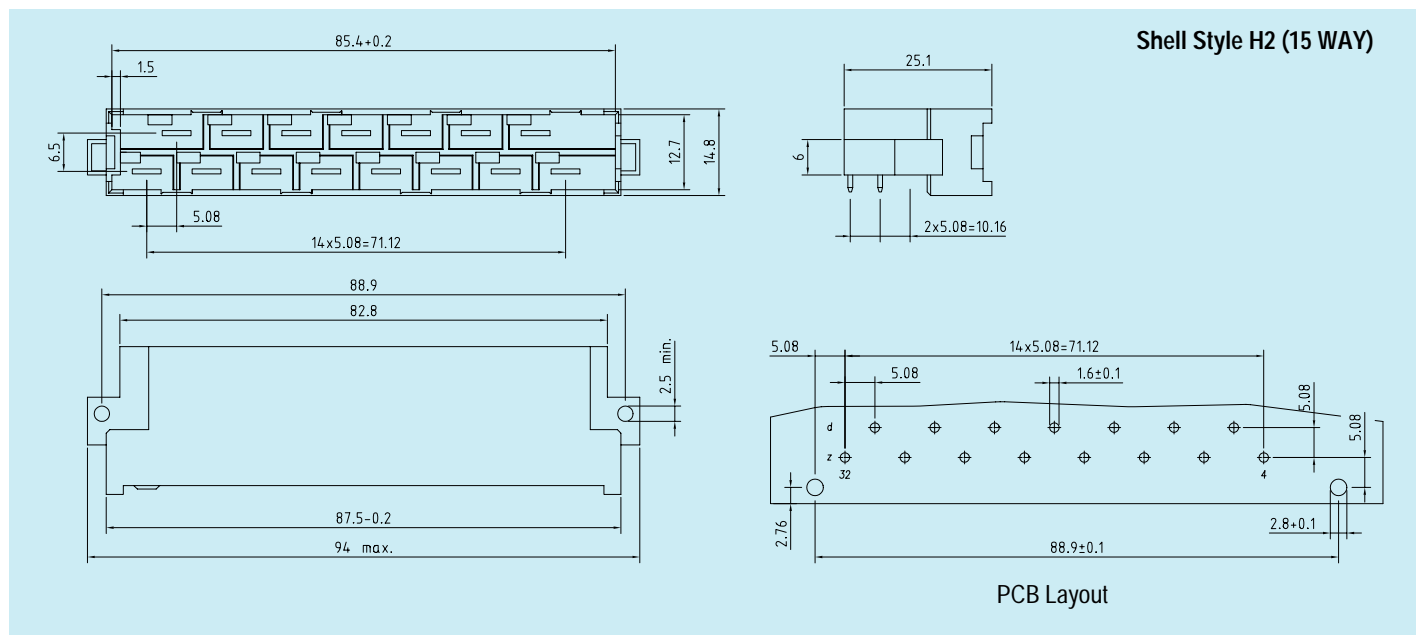
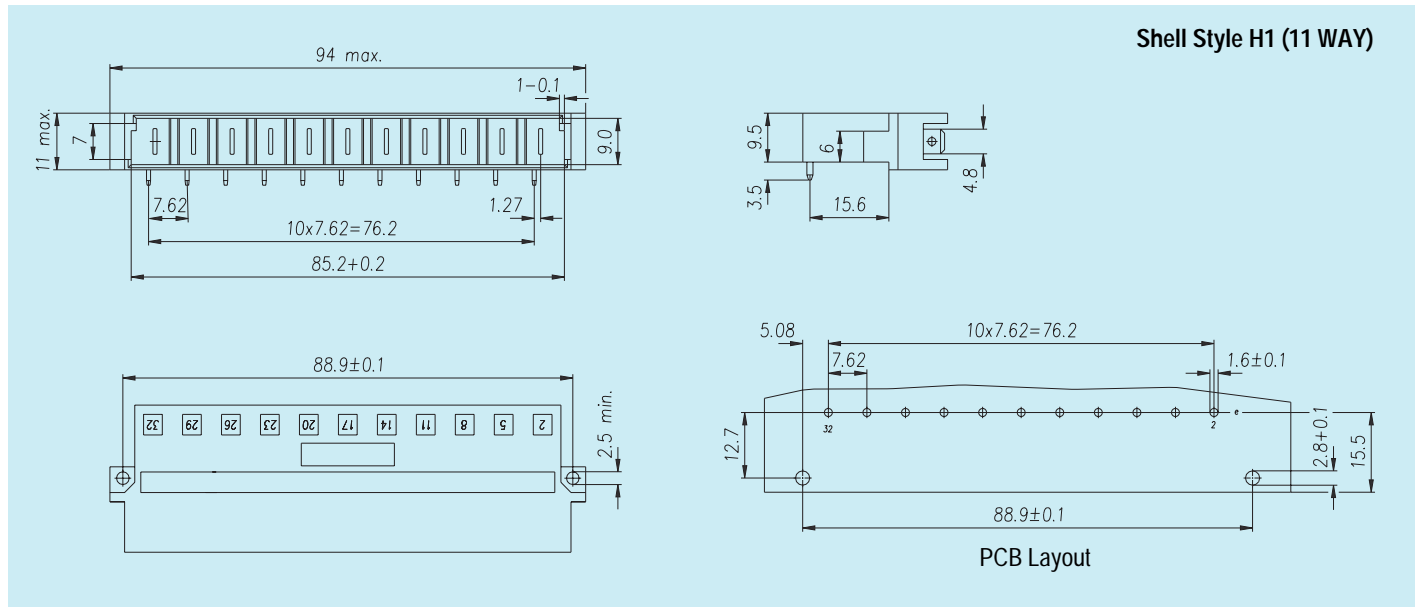

Termination	Terminal	Shell Style	Cavities with Pre-mating Contacts	Contact Loading Pattern	Ordering Code
	Solder	H1 (11 way)		11 way fully loaded	CDR7H1M11RS3M
		H1 (11 way)	32	11 way fully loaded	CDR7H1M11RS3M-32E
		H1 (11 way)	2 & 32	11 way fully loaded	CDR7H1M11RS3M-2E32
		H2 (15 way)	Z32	15 way fully loaded	CDR7H2M15RS2M-32Z
	Solder	H2 (15 way)	Z4 & Z32	15 way fully loaded	CDR7H2M15RS2M-4Z32

Female Connectors

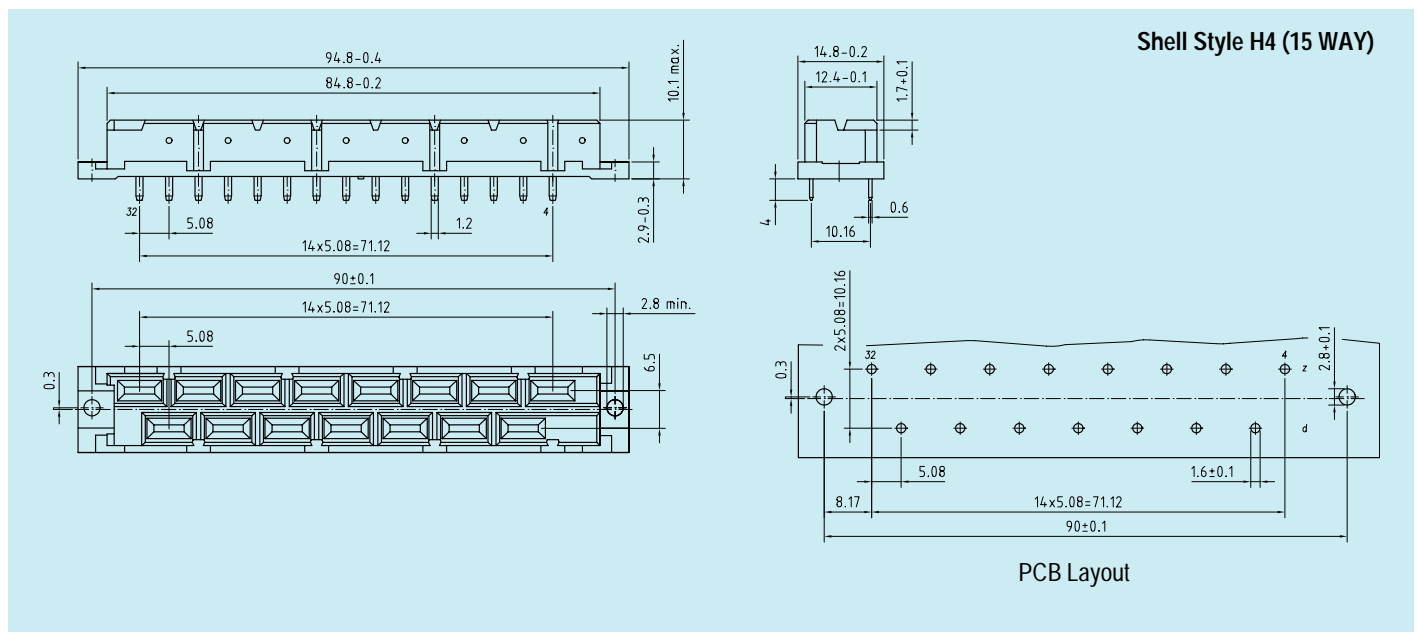
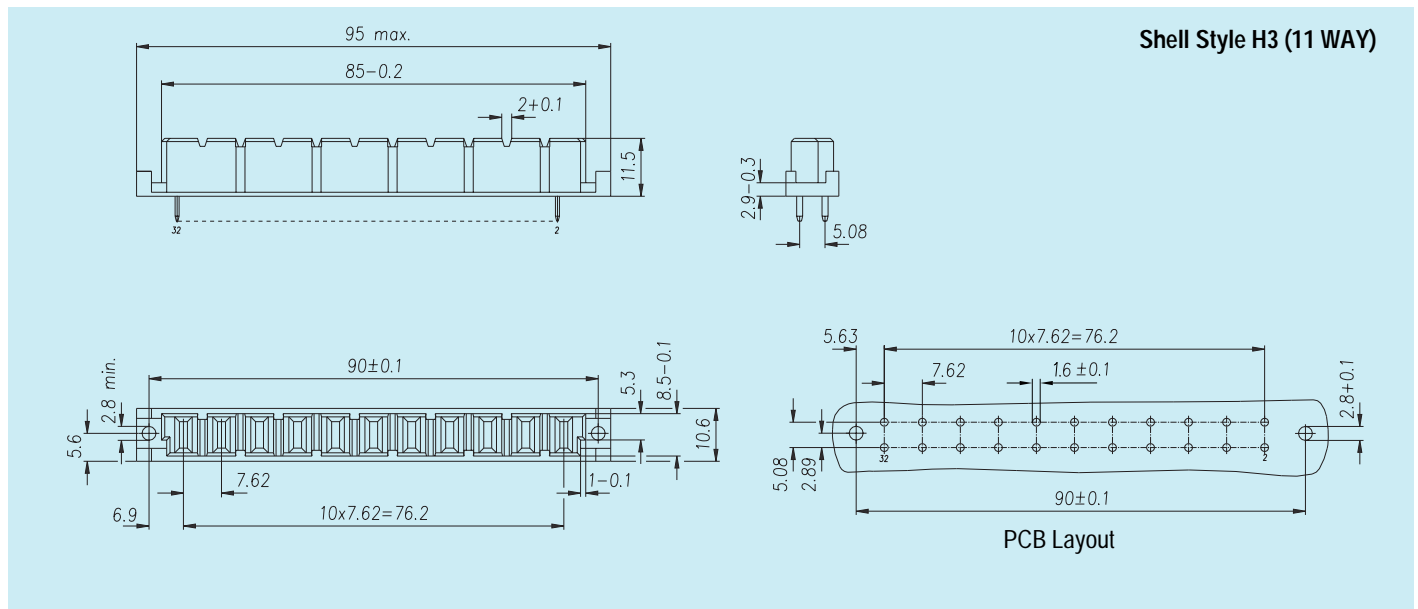

Termination	Terminal	Shell Style	Contact Loading Pattern	Ordering Code
	Solder	H3 (11 way)	11 way fully loaded	CDR7H3F11TS6M
	Solder	H4 (15 way)	15 way fully loaded	CDR7H4F15TS4M
	Solder	H4 (15 way)	15 way fully loaded	CDR7H4F15TS8M

Male Connectors

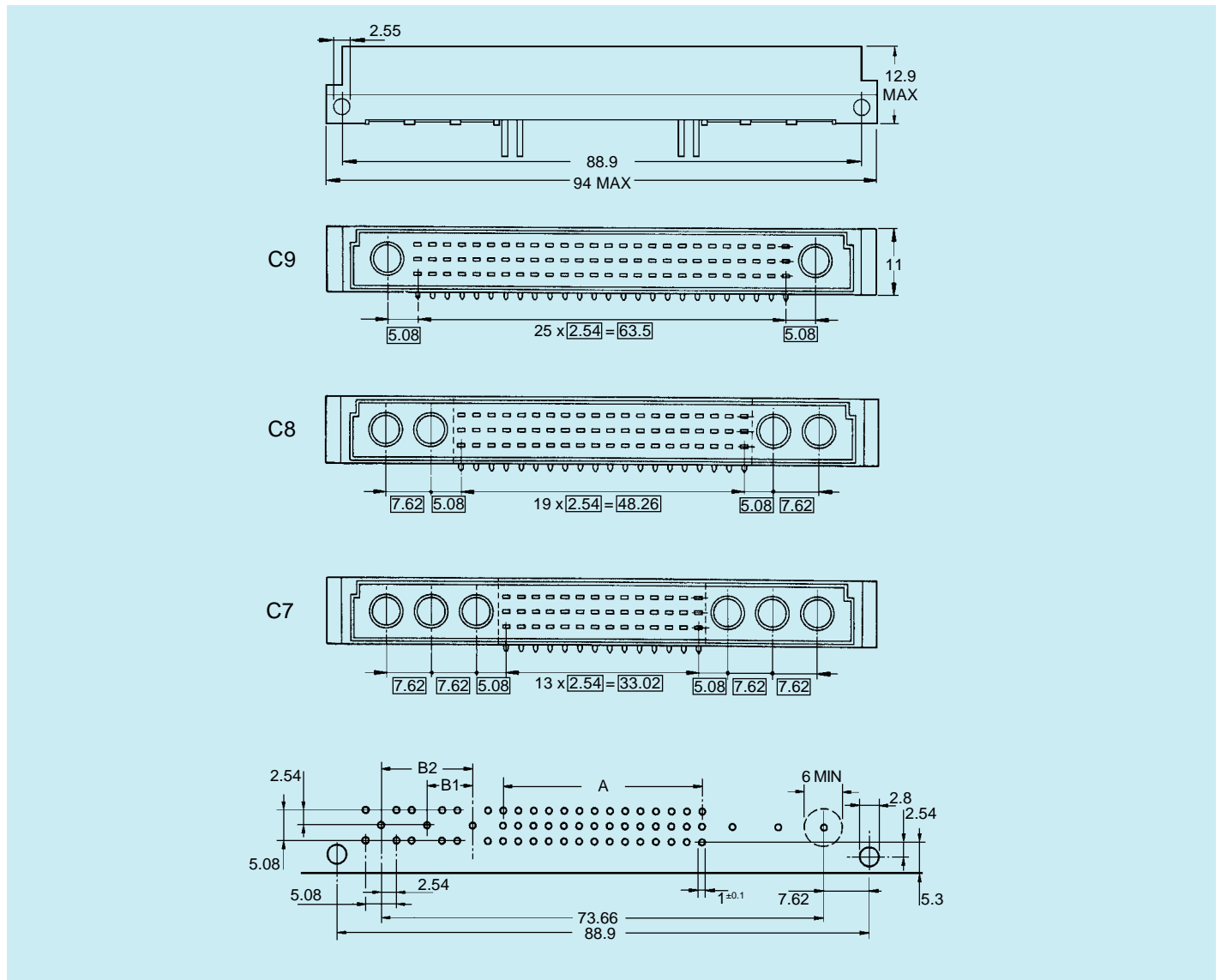

Termination	Terminal	Plating Class	Shell Style	Signal Contact Loading Pattern	Dimensions			Ordering Code
					A	B1	B2	
	Solder	DIN 2	C7 (3 x 14 signal + 6 insert cavities)	42 way fully loaded	13 x 2,54 = 33,02	7,62	15,24	CDR7C7M42RS2M-DIN2
			C8 (3 x 20 signal + 4 insert cavities)	60 way fully loaded	19 x 2,54 = 48,26	7,62		CDR7C8M60RS2M-DIN2
			C9 (3 x 26 signal + 2 insert cavities)	78 way fully loaded	25 x 2,54 = 63,50			CDR7C9M78RS2M-DIN2

For class 1 or class 3 contact plating and for alternative loading patterns please consult Cannon Sales Department.

Female Connectors

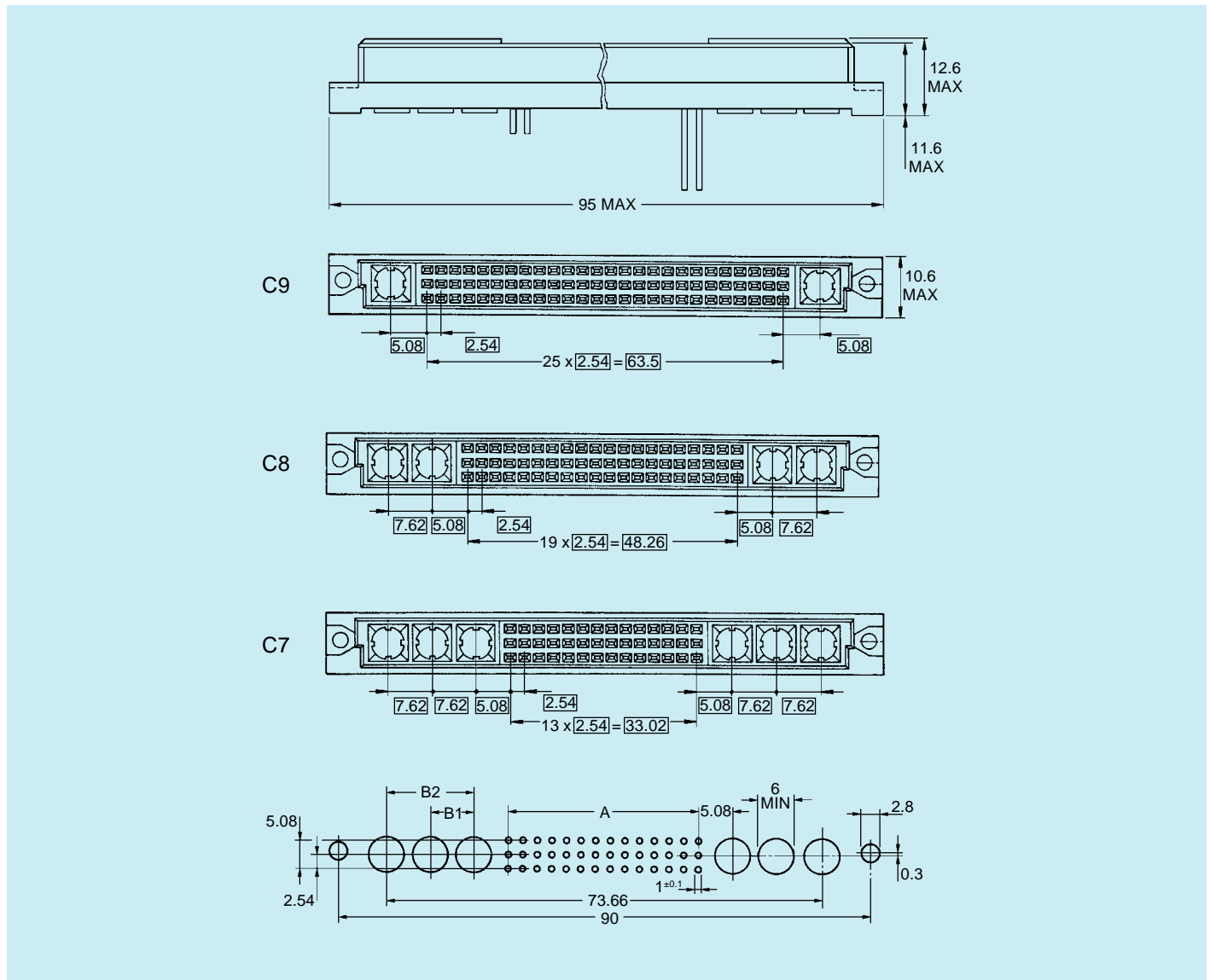

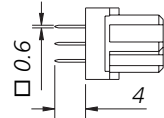
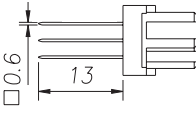
Termination	Terminal	Plating Class	Shell Style	Signal Contact Loading Pattern	Dimensions			Ordering Code
					A	B1	B2	
	Solder	DIN 2	C7 (3 x 14 signal + 6 insert cavities)	42 way fully loaded	13 x 2,54 = 33,02	7,62	15,24	CDR7C7F42TS4M-DIN2
			C8 (3 x 20 signal + 4 insert cavities)	60 way fully loaded	19 x 2,54 = 48,26	7,62		CDR7C8F60TS4M-DIN2
			C9 (3 x 26 signal + 2 insert cavities)	78 way fully loaded	25 x 2,54 = 63,50			CDR7C9F78TS4M-DIN2
	Solder	DIN 2	C7 (3 x 14 signal + 6 insert cavities)	42 way fully loaded	13 x 2,54 = 33,02	7,62	15,24	CDR7C7F42TS8M-DIN2
			C8 (3 x 20 signal + 4 insert cavities)	60 way fully loaded	19 x 2,54 = 48,26	7,62		CDR7C8F60TS8M-DIN2
			C9 (3 x 26 signal + 2 insert cavities)	78 way fully loaded	25 x 2,54 = 63,50			CDR7C9F78TS8M-DIN2

For class 1 or class 3 contact plating and for alternative loading patterns please consult Cannon Sales Department.

High Power Female Inserts - Straight, Solder Terminated

Current Rating	FMLB*	A	B	C	Ordering Code
10A		1.8	2.6	21.8	031-7733-000
20A		2.8	3.7	21.8	031-7731-000
40A		4.8	5.6	21.8	031-7729-000
10A	✓	1.8	2.6	22.3	031-7739-000
20A	✓	2.8	3.7	22.3	031-7737-000
40A	✓	4.8	5.6	22.3	031-7735-000

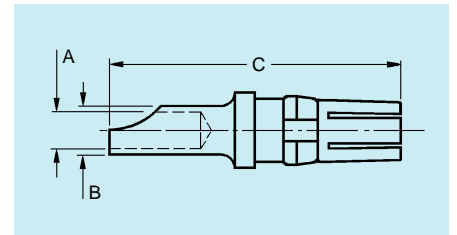

High Power Male Inserts - Straight, Solder Terminated

Current Rating	FMLB*	A	B	C	Ordering Code
10A		1.8	2.6	22.0	031-7732-000
20A		2.8	3.7	22.0	031-7730-000
40A		4.8	5.6	22.0	031-7728-000
10A	✓	1.8	2.6	23.0	031-7738-000
20A	✓	2.8	3.7	23.0	031-7736-000
40A	✓	4.8	5.6	23.0	031-7734-000

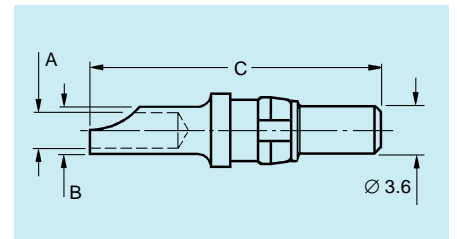

High Power Male Inserts - Right Angle, PCB Mount

Current Rating	FMLB*	C	Ordering Code
40A		17.35	031-7726-000
40A	✓	18.40	031-7725-000

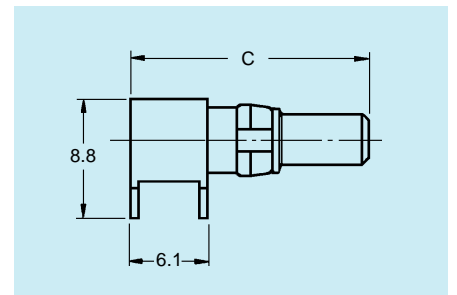

* FMLB = First to Make / Last to Break

Coaxial Plugs for Female Connectors

Contact Style	50Ω Cable Type	75Ω Cable Type	Ordering Code
Straight, coax cable mount	RG174A/U	RG179B/U	077335-0001
	RG188A/U	RG187A/U	
	RG316/U		

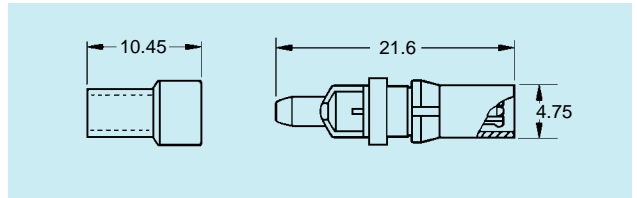

Contact Style	50Ω Cable Type	75Ω Cable Type	Ordering Code
90°, coax cable mount	RG174A/U	RG179B/U	077335-0005
	RG188A/U	RG187A/U	
	RG316/U		

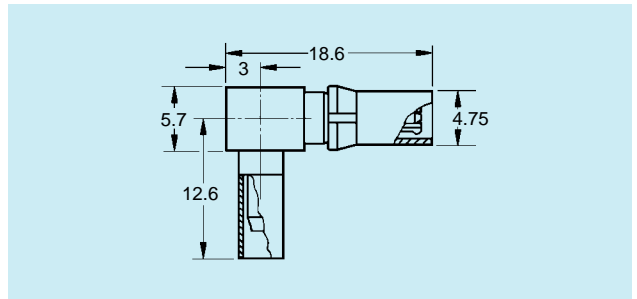

Coaxial Jacks for Male Connectors

Contact Style	50Ω Cable Type	75Ω Cable Type	Ordering Code
Straight, coax cable mount	RG174A/U	RG179B/U	077335-0004
	RG188A/U	RG187A/U	
	RG316/U		

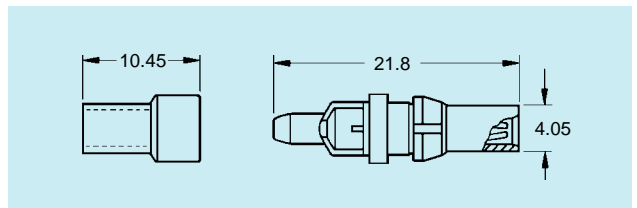

Contact Style	Ordering Code
90°, PCB mount	077335-0002

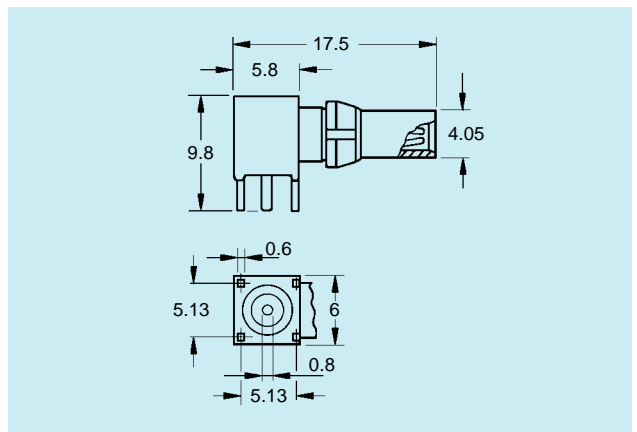

Assembly of Coaxial Cable

The centre conductor of the cable is soldered into the contact.

The ferrule can be either soldered or crimped around the cable braid (consult Cannon Sales Department for crimp tooling).

A	B	C	Contact Part Number
6.4	7.9	2.0	077335-0001
			077335-0004
6.0	9.5	1.6	077335-0005

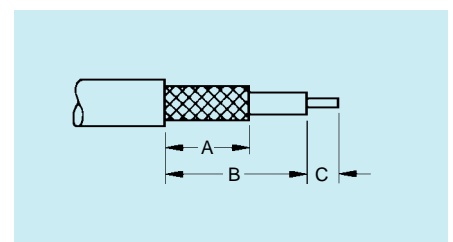

Introduction

E2X cable connectors were designed for the Telecoms industry, but due to their flexibility are used in other areas such as computing, datacoms and process control.

The design concept is based on modular 9, 14, 21, 45, 64 and 96 way cable connectors plugged onto the extended contact tails of standard and reverse DIN41612 PCB connectors (styles C and R).

The cable connectors have IDC contacts which accept 26 or 30 AWG discrete wire or ribbon cable. Uninsulated drain wires can also be terminated without the need for additional insulation sleeves.

Latching and polarisation is achieved through tabs on the cable connectors and latchframes fitted to the PCB connectors.

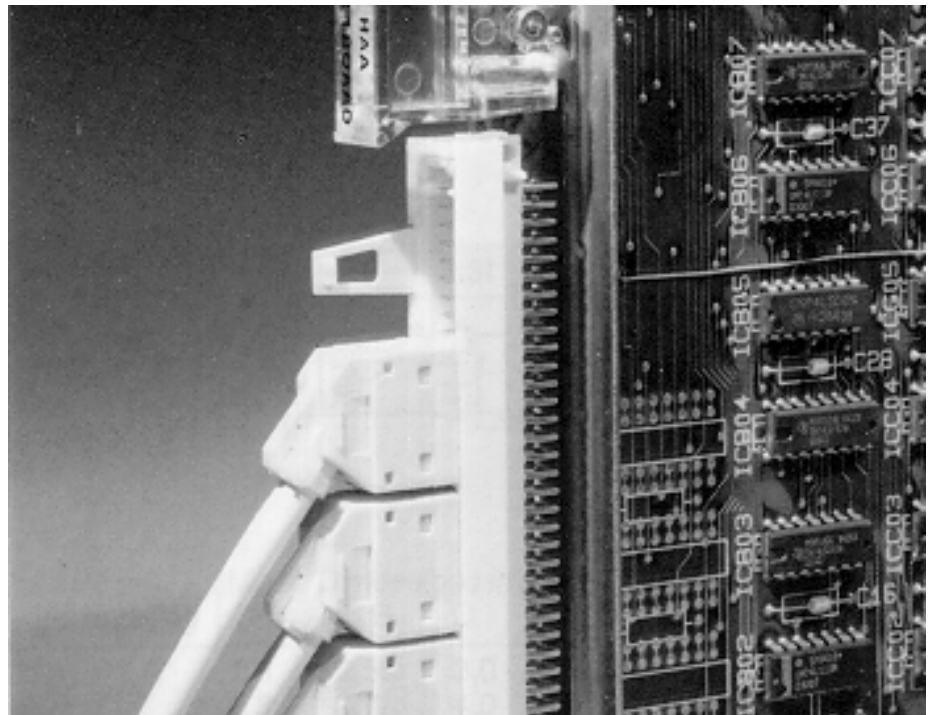

Specifications

MATERIALS

Contacts	Beryllium Copper
Mouldings	Glass filled thermoplastic, UL 94V-0 rated
Plating	Contact area: Au/Ni. Termination area: SnPb.

ELECTRICAL

Current rating	1 A at 70°C. 1.5 A at 25°C
Working voltage	350 VAC continuous
DWV	1050 VAC maximum for 60 seconds
Contact resistance	15 mΩ maximum

MECHANICAL

Mating force	1 N maximum per contact
Unmating force	0.2 N minimum per contact
Cable conductor size	26 AWG/0.4mm 30 AWG/0.25mm
Cable insulation	0.85mm - 0.6mm Approved insulator materials polypropylene, polyethylene

Accessories

Description	Ordering Code
Shroud	391-7509-102

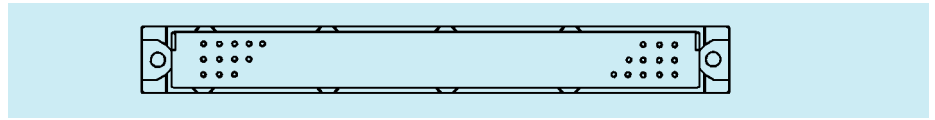

Description	Ordering Code
Polarised Latchframe	068-7507-000

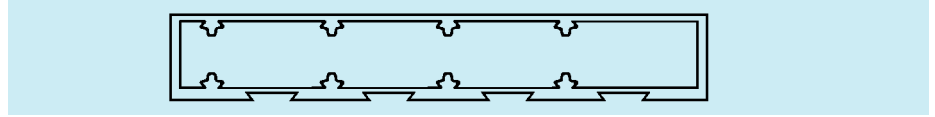

Description	Ordering Code
Unpolarised Latchframe	068-7507-001

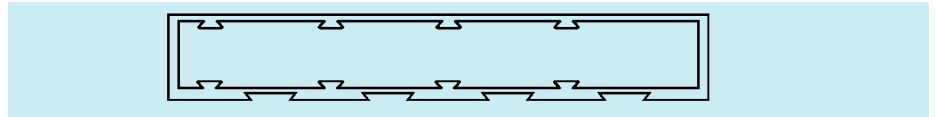

Description	Ordering Code
Long Latch (A)	207-7508-000
Short Latch (B)	207-7507-000

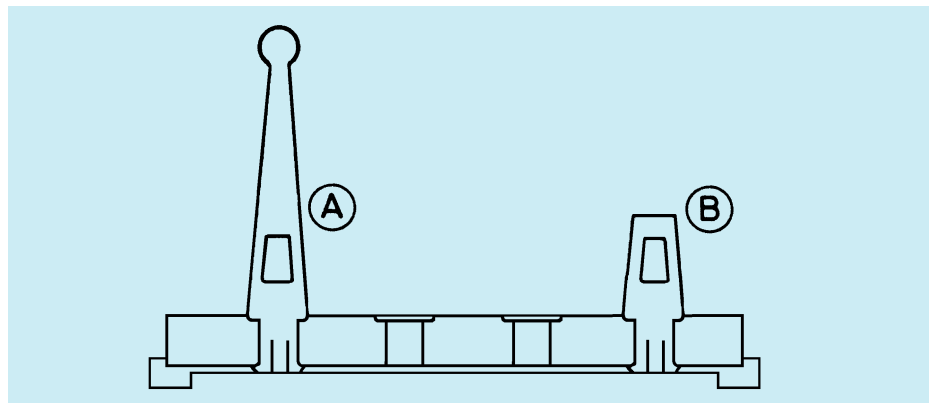

Description	Ordering Code
Shroud + Polarised Latchframe + 4 Short Latches	077734-0000

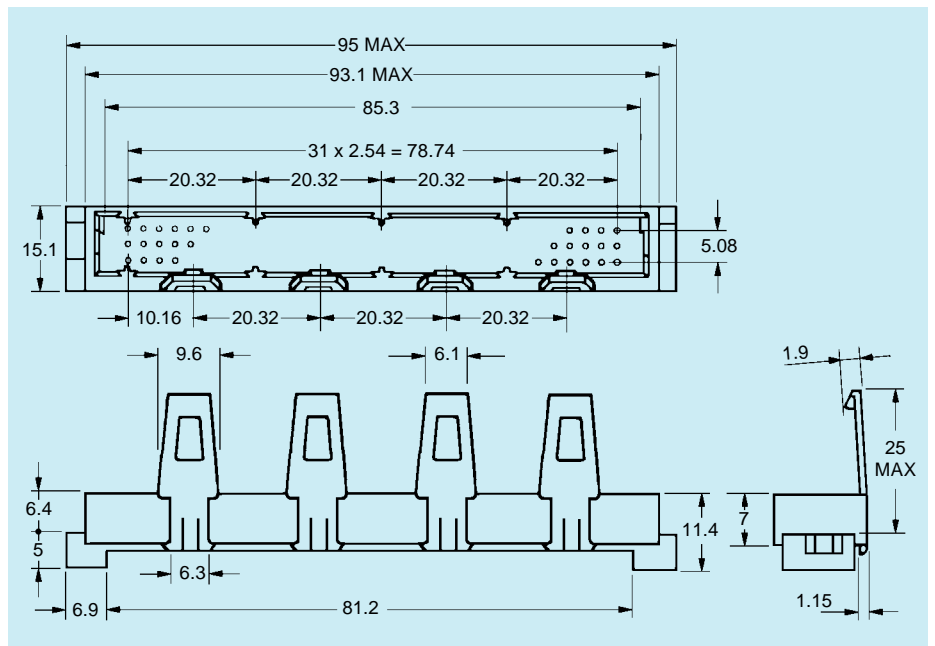

Hand Termination Tools (NOT ILLUSTRATED)

Description	Ordering Code
14 way ribbon cable	274-7540-001
64 way ribbon cable	274-7540-002
9, 21, 45, 64 & 96 way discrete wire	077350-1029

96 and 64 Way

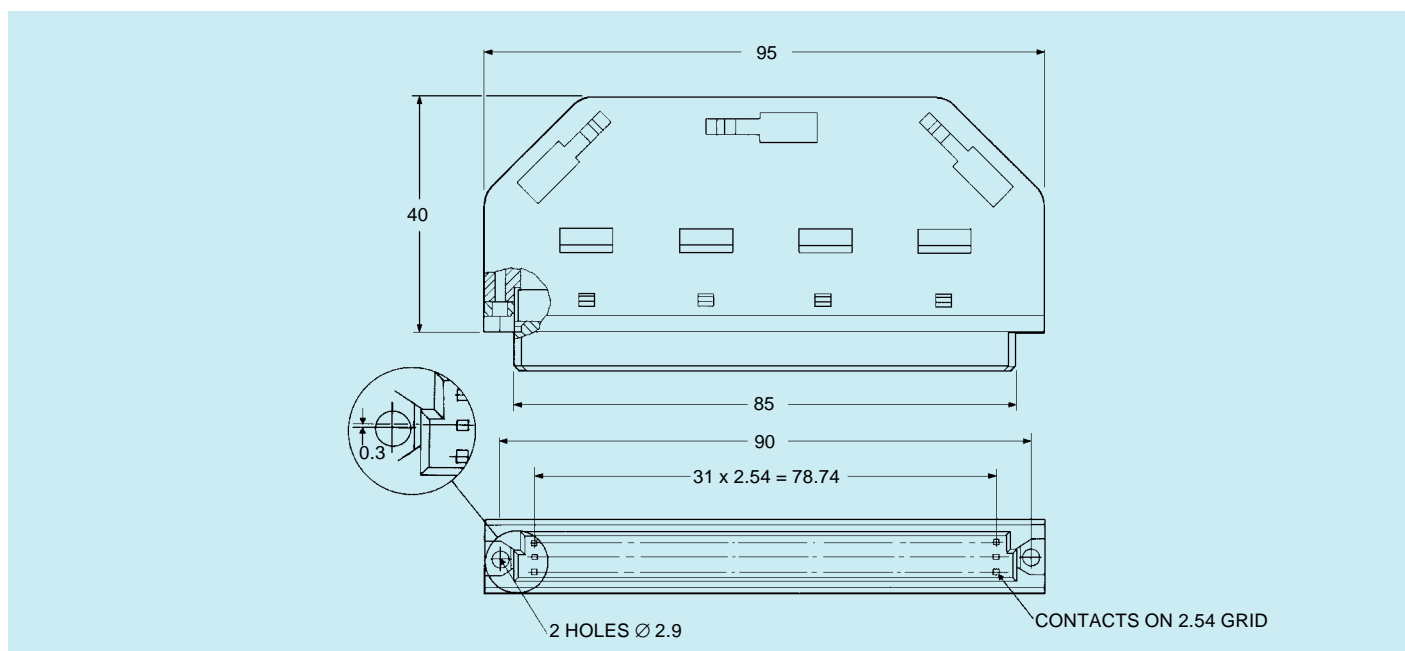

Termination Style	Plating Class	Wire Size	Contact Loading Pattern	Ordering Code
Discrete wire IDC	DIN 1	30 AWG 0.25mm	96 way rows a, b & c	E2XF960AAI1COA
Discrete wire IDC	DIN 1	26AWG 0.4mm	96 way rows a, b & c	E2XF960AAI2COA
Discrete wire IDC	DIN 1	30 AWG 0.25mm	64 way rows a & c	E2XF960ARI1COA
Discrete wire IDC	DIN 1	26AWG 0.4mm	64 way rows a & c	E2XF960ARI2COA

14 and 64 Way

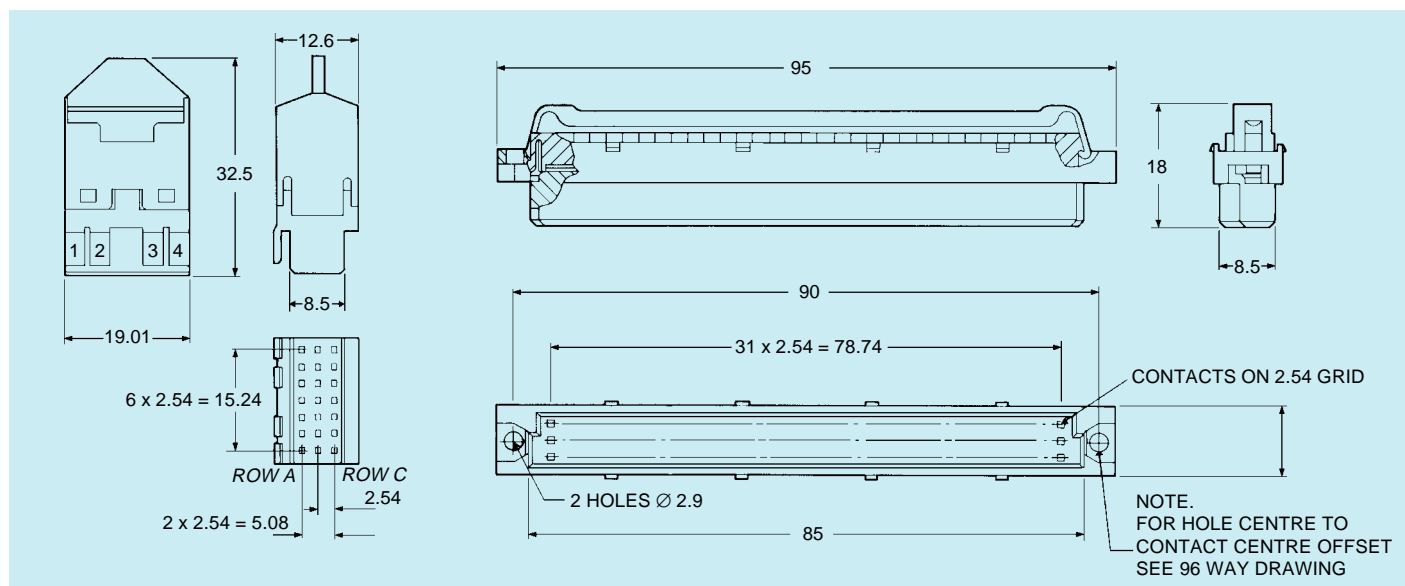

Termination Style	Plating Class	Wire Size	Contact Loading Pattern	Ordering Code
IDC ribbon cable	DIN 1	30 AWG 0.25mm	64 way rows a & c	E2XF960ARI1ROA
IDC ribbon cable	DIN 1	26AWG 0.4mm	64 way rows a & c	E2XF960ARI2ROA
IDC ribbon cable	DIN 1	30 AWG 0.25mm	14 way rows a & c	E2XF210DNI1ROA
IDC ribbon cable	DIN 1	26AWG 0.4mm	14 way rows a & c	E2XF210DNI2ROA

45, 30, 21 and 14 Way

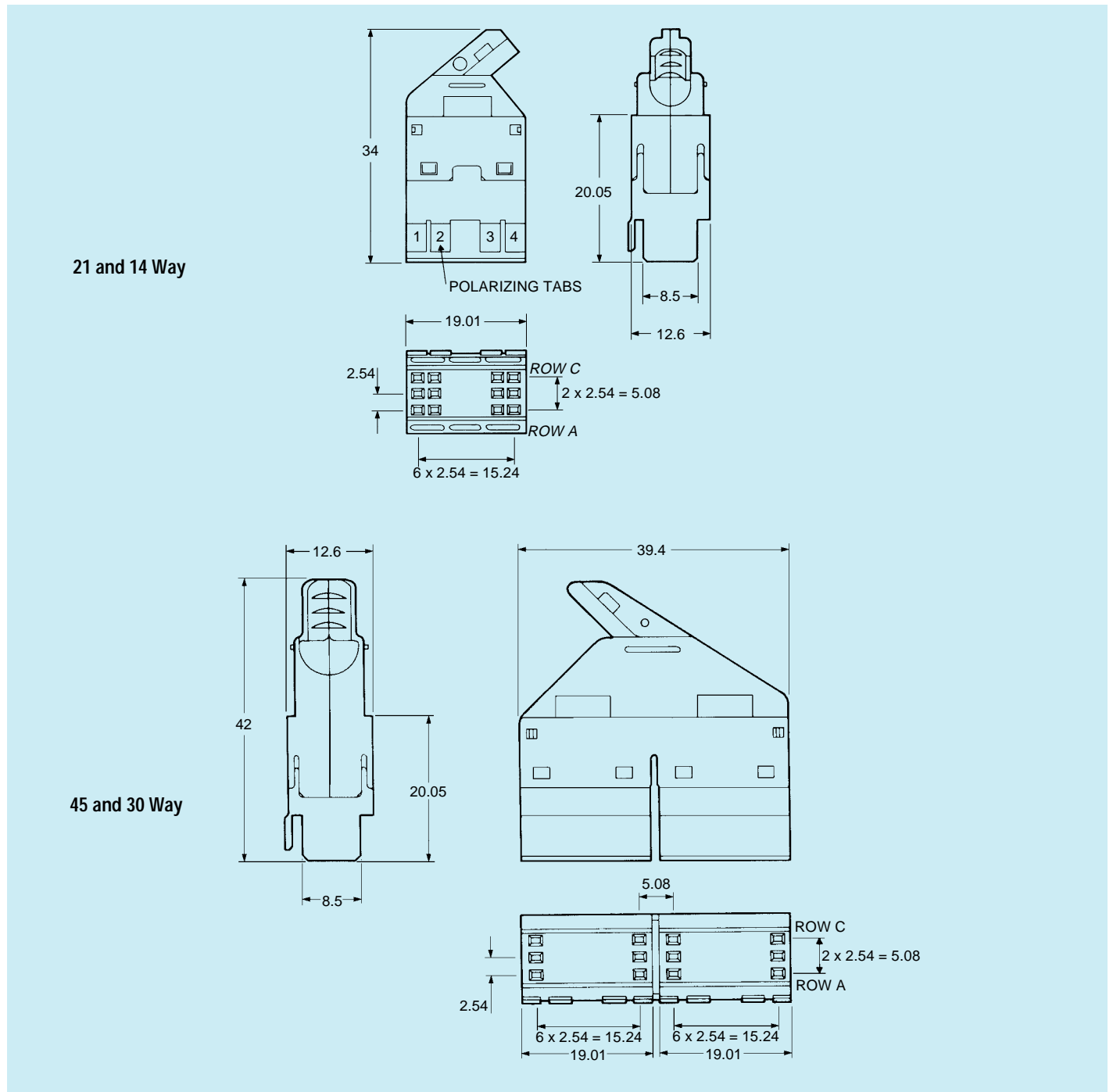

Termination Style	Plating Class	Wire Size	Contact Loading Pattern	Ordering Code
Discrete wire IDC	DIN 1	30 AWG 0.25mm	21 way rows a, b & c	E2XF210DMI1COA
Discrete wire IDC	DIN 1	26AWG 0.4mm	21 way rows a, b & c	E2XF210DMI2COA
Discrete wire IDC	DIN 1	30 AWG 0.25mm	14 way rows a & c	E2XF210DNI1COA
Discrete wire IDC	DIN 1	26AWG 0.4mm	14 way rows a & c	E2XF210DNI2COA
Discrete wire IDC	DIN 1	30 AWG 0.25mm	45 way rows a, b & c	E2XF450FDI1COA
Discrete wire IDC	DIN 1	26AWG 0.4mm	45 way rows a, b & c	E2XF450FDI2COA
Discrete wire IDC	DIN 1	30 AWG 0.25mm	30 way rows a & c	E2XF450FEI1COA
Discrete wire IDC	DIN 1	26AWG 0.4mm	30 way rows a & c	E2XF450FEI2COA

9 and 6 Way and Coaxial

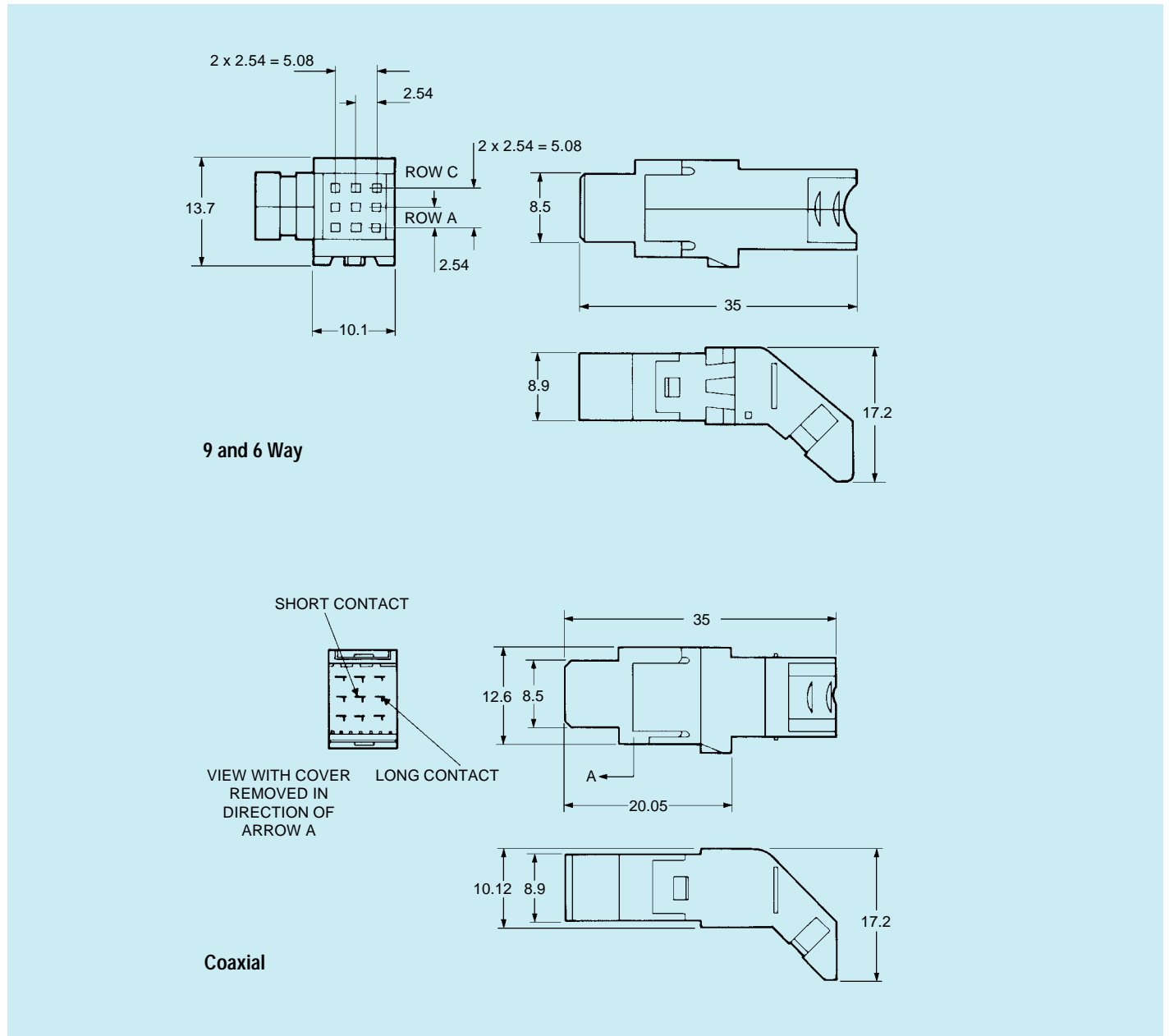

Termination Style	Plating Class	Wire Size	Contact Loading Pattern	Ordering Code
Coax, solder	DIN 1		single coax contacts	E2XF090DSI3POA
Discrete wire IDC	DIN 1	30 AWG 0.25mm	9 way rows a, b & c	E2XF090DPI1COA
Discrete wire IDC	DIN 1	26AWG 0.4mm	9 way rows a, b & c	E2XF090DPI2COA
Discrete wire IDC	DIN 1	30 AWG 0.25mm	6 way rows a & c	E2XF090DQI1COA
Discrete wire IDC	DIN 1	26AWG 0.4mm	6 way rows a & c	E2XF090DQI2COA

What do you mean, "Pressfit contact"?

In every job speciality there are certain words and phrases used by the "insiders" which after a time become almost a language unique to that speciality. Printed circuit board connectors are a typical example of that condition.

This page provides some explanations, in an attempt to clarify some of the terms that are commonly used by engineers and sales staff at Cannon.

The list is not comprehensive, but highlights many of the expressions commonly used. Should you have any comments or additions please contact us. Feedback will be appreciated.

Air gap — The shortest straight line distance through the air between 2 conductors.

AWG — American Wire Gauge is a standard for wire diameters based on the approximate circular mil area of the wire. The larger the AWG number, the smaller the diameter of the wire.

Boardlocks — Components which can be supplied fitted in the connector which snap into holes on the Printed Circuit Board, so giving additional support to the connector before and after soldering.

CDR7 — Is the name given by Cannon to their PCB mount connectors which conform to DIN41612.

Coaxial cable — A transmission line where the one conductor is concentric inside another; often abbreviated to 'coax'.

Coding — When many DIN connectors of the same style are used on the backplane it is sometimes necessary to mechanically code mating connectors so that only those two connectors, and no others, can be mated together.

Combination layout — A connector that combines low frequency contacts (which are fitted) with empty cavities that can be used to hold radio frequency or high power contacts (which are bought separately).

Contact resistance — The measurement of the DC electrical resistance between a pair of mated contacts. Usually specified as being measured after a given number of mating cycles.

Creepage — The shortest distance along the surface of the insulator between 2 conductors.

Current rating — The maximum current that can continuously flow through two mated contacts without raising the temperature above the specified maximum operating level. The higher the ambient temperature, the less room there is for heat rise generated by the current going through the contacts.

DIN41612 — The Deutsches Institut für Normung is a German standards organisation. Their 41612 specifications cover two part connectors (i.e. male and female) for Printed Circuit Boards on a 2.54mm grid.

DWV — The Dielectric Withstanding Voltage is the maximum voltage that the insulator will allow to be put through the contacts without risk of a flashover between contacts.

E2X — Is the name given by Cannon to their cable terminated connectors which mate with DIN41612 PCB mount connectors.

First-to-make and last-to-make contacts — An extended contact, which is longer than the contacts around it, will be the first connection made as two connectors are mated and the last connection to be broken as they are unmated. Such contacts are often used to establish a ground connection. Similarly a contact which is shorter than those surrounding it will be the last connection to be made as two connectors are mated, and so will often be used to carry power.

Hertz (Hz) — A measure of frequency representing cycles per second.

IDC — An Insulation Displacement Contact has a "V" shaped terminal that cuts through the insulation material around a wire to make a gas tight connection with the centre conductor. This process eliminates the need for stripping the insulating material from the wire and allows many contacts to be terminated simultaneously.

Insulation resistance — The electrical resistance between two conductors separated by an insulating medium.

Mating force — The force required to mate two connectors.

Ohm (Ω) — A measure of DC resistance or RF impedance.

PCB — Printed Circuit Board.

Plastic keys — Supplied as accessories, these are used in the coding of shell style B and C connectors. They are formed plastic components that snap into cavities on both sides of the female insulator. A corresponding section of the insulator wall of the male connector is then broken out with a special tool to allow the connectors to mate together.

Plating class — DIN41612 part 5 defines three levels of plating performance. DIN class 1 plating guarantees 500 mating cycles, with a 21 day industrial atmosphere test after 250 cycles have been performed. The base material of the contact should not be exposed after the 500 cycles are completed. DIN class 2 guarantees 400 mating cycles, with a 4 day industrial atmosphere test performed after 200 cycles. DIN class 3 guarantees 50 mating cycles with no industrial atmosphere test.

Pressfit contact — A contact with a compliant section in its tail which compresses when pressed into a plated through hole in the PCB to form a gas tight connection. Pressfitting connectors is a clean process which puts no thermal stress on the PCB and has none of the cold joint or bridging problems associated with soldering.

Pressfit insertion die — A tool which is fitted inside a press and which is designed to apply the press force onto the correct positions of the contacts and/or insulator so that all the pressfit contacts in a connector are terminated simultaneously.

Rear plug-up — A PCB terminated connector with extended contact tails can allow a compatible female connector to be plugged onto the contact tails.

Shell style — The form and dimensions of the connector housing, as defined in the DIN41612 specifications.

UL — Underwriters Laboratories is an American safety standards organisation. UL 94V-O is a widely recognised flammability rating.

Wire wrapping — Making connections between contacts by wrapping the uninsulated ends of a wire around the extended tails of the contacts. Approved wire wrapping methods are defined in DIN41611 part 2

Working voltage — The voltage at which the connector can operate continuously under normal conditions

Part Number	Page Number	Part Number	Page Number	Part Number	Page Number	Part Number	Page Number
884100	7	CDR7B1F64TP2M-DIN2	7	CDR7C3F30TS8M-DIN2	10	CDR7R1F64RS2M-004-DIN2	12
884101	7	CDR7B1F64TP5M-DIN2	7	CDR7C3M30RP1M-DIN2	8	CDR7R1F96RP1M-DIN2	12
884102	7	CDR7B1F64TS4M-DIN2	7	CDR7C3M30RS2M-DIN2	8	CDR7R1F96RS2M-DIN2	12
884150	6	CDR7B1F64TS8M-DIN2	7	CDR7C7F42TS4M-DIN2	25	CDR7R1M64TP2M-004-DIN2	11
884151	6	CDR7B1M64RP1M-DIN2	6	CDR7C7F42TS8M-DIN2	25	CDR7R1M64TP5M-004-DIN2	11
884152	6	CDR7B1M64RS2M-DIN2	6	CDR7C7M42RS2M-DIN2	24	CDR7R1M64TS4M-004-DIN2	11
884250	8	CDR7B2F32TP2M-DIN2	7	CDR7C8F60TS4M-DIN2	25	CDR7R1M64TS8M-004-DIN2	11
884251	8	CDR7B2F32TP5M-DIN2	7	CDR7C8F60TS8M-DIN2	25	CDR7R1M96TP2M-DIN2	11
884252	8	CDR7B2F32TS4M-DIN2	7	CDR7C8M60RS2M-DIN2	24	CDR7R1M96TP5M-DIN2	11
884303	14	CDR7B2F32TS8M-DIN2	7	CDR7C9F78TS4M-DIN2	25	CDR7R1M96TS4M-DIN2	11
884353	16	CDR7B2M32RP1M-DIN2	6	CDR7C9F78TS8M-DIN2	25	CDR7R1M96TS8M-DIN2	11
884401	18	CDR7B2M32RS2M-DIN2	6	CDR7C9M78RS2M-DIN2	24	CDR7R2F32RP1M-004-DIN2	12
884406	19	CDR7B3F20TP2M-DIN2	7	CDR7D1F32TP2M-DIN2	14	CDR7R2F32RS2M-004-DIN2	12
884453	21	CDR7B3F20TP5M-DIN2	7	CDR7D1F32TP8M-DIN2	14	CDR7R2F48RP1M-DIN2	12
884500	12	CDR7B3F20TS4M-DIN2	7	CDR7D1F32TS5M-DIN2	14	CDR7R2F48RS2M-DIN2	12
884501	12	CDR7B3F20TS8M-DIN2	7	CDR7D1F32TS9M-DIN2	14	CDR7R2M32TP2M-004-DIN2	11
884525	11	CDR7B3M20RP1M-DIN2	6	CDR7D1M32RS2M-DIN2	13	CDR7R2M32TP5M-004-DIN2	11
884526	11	CDR7B3M20RS2M-DIN2	6	CDR7E1F48TP2M-DIN2	16	CDR7R2M32TS4M-004-DIN2	11
886900	9	CDR7C1F64TP2M-004-DIN2	9	CDR7E1F48TP8M-DIN2	16	CDR7R2M32TS8M-004-DIN2	11
031-7728-000	26	CDR7C1F64TP5M-004-DIN2	9	CDR7E1F48TS5M-DIN2	16	CDR7R2M48TP2M-DIN2	11
031-7729-000	26	CDR7C1F64TS4M-004-DIN2	10	CDR7E1F48TS9M-DIN2	16	CDR7R2M48TP5M-DIN2	11
031-7730-000	26	CDR7C1F64TS8M-004-DIN2	10	CDR7E1M48RS1M-DIN2	15	CDR7R2M48TS4M-DIN2	11
031-7731-000	26	CDR7C1F96TP2M-DIN2	9	CDR7E2M48RS1M-DIN2	15	CDR7R2M48TS8M-DIN2	11
031-7732-000	26	CDR7C1F96TP5M-DIN2	9	CDR7F1F48TP2M-DIN2	18	E2XF090DPI1C0A	32
031-7733-000	26	CDR7C1F96TS4M-DIN2	10	CDR7F1F48TP8M-DIN2	18	E2XF090DPI2C0A	32
031-7734-000	26	CDR7C1F96TS8M-DIN2	10	CDR7F1F48TS5M-DIN2	18	E2XF090DQI1C0A	32
031-7735-000	26	CDR7C1M64RP1M-004-DIN2	8	CDR7F1F48TS9M-DIN2	18	E2XF090DQI2C0A	32
031-7735-000	26	CDR7C1M64RS2M-004-DIN2	8	CDR7F1M48RS2M-DIN2	17	E2XF090DSI3P0A	32
031-7737-000	26	CDR7C1M96RP1M-DIN2	8	CDR7F2F48TP2M-DIN2	19	E2XF210DMI1C0A	31
031-7738-000	26	CDR7C1M96RS2M-DIN2	8	CDR7F2F48TP5M-DIN2	19	E2XF210DMI2C0A	31
031-7739-000	26	CDR7C2F32TP2M-004-DIN2	9	CDR7F2F48TS5M-DIN2	19	E2XF210DNI1C0A	31
068-7507-000	29	CDR7C2F32TP5M-004-DIN2	9	CDR7G1F64TP2M-DIN2	21	E2XF210DNI1ROA	30
068-7507-001	29	CDR7C2F32TS4M-004-DIN2	10	CDR7G1F64TP8M-DIN2	21	E2XF210DNI2C0A	31
077335-0001	27	CDR7C2F32TS8M-004-DIN2	10	CDR7G1F64TS5M-DIN2	21	E2XF210DNI2ROA	30
077335-0002	27	CDR7C2F48TP2M-DIN2	9	CDR7G1F64TS9M-DIN2	21	E2XF450FDI1C0A	31
077335-0004	27	CDR7C2F48TP5M-DIN2	9	CDR7G1M64RS2M-DIN2	20	E2XF450FDI2C0A	31
077335-0005	27	CDR7C2F48TS4M-DIN2	10	CDR7H1M11RS3M	22	E2XF450FE1C0A	31
077350-1029	29	CDR7C2F48TS8M-DIN2	10	CDR7H1M11RS3M-2E32	22	E2XF450FEI2C0A	31
077734-0000	29	CDR7C2M32RP1M-004-DIN2	8	CDR7H1M11RS3M-32E	22	E2XF960AAI1C0A	30
207-7507-000	29	CDR7C2M32RS2M-004-DIN2	8	CDR7H2M15RS2M-32Z	22	E2XF960AAI2C0A	30
207-7508-000	29	CDR7C2M48RP1M-DIN2	8	CDR7H2M15RS2M-4Z32	22	E2XF960ARI1C0A	30
274-7540-001	29	CDR7C2M48RS2M-DIN2	8	CDR7H3F11TS6M	23	E2XF960ARI1ROA	30
274-7540-002	29	CDR7C3F30TP2M-DIN2	9	CDR7H4F15TS4M	23	E2XF960ARI2C0A	30
391-7509-102	29	CDR7C3F30TP5M-DIN2	9	CDR7H4F15TS8M	23	E2XF960ARI2ROA	30
		CDR7C3F30TS4M-DIN2	10	CDR7R1F64RP1M-004-DIN2	12		

Product Safety Information

THIS NOTE MUST BE READ IN CONJUNCTION WITH THE PRODUCT DATA SHEET/CATALOG. FAILURE TO OBSERVE THE ADVICE IN THIS INFORMATION SHEET AND THE OPERATING CONDITIONS SPECIFIED IN THE PRODUCT DATA SHEET/CATALOG COULD RESULT IN HAZARDOUS SITUATIONS.

1 MATERIAL CONTENT AND PHYSICAL FORM

Electrical connectors do not usually contain hazardous materials. They contain conducting and non-conducting materials and can be divided into two groups.

a) Printed circuit types and low cost audio types which employ all plastic insulators and casings.

b) Rugged, Fire Barrier and High Reliability types with metal casings and either natural rubber, synthetic rubber, plastic or glass insulating materials. Contact materials vary with type of connector and also application and are usually manufactured from either: Copper, copper alloys, nickel, alumel, chromel or steel. In special applications, other alloys may be specified.

2 FIRE CHARACTERISTICS AND ELECTRIC SHOCK HAZARD

There is no fire hazard when the connector is correctly wired and used within the specified parameters. Incorrect wiring or assembly of the connector or careless use of metal tools or conductive fluids, or transit damage to any of the component parts may cause electric shock or burns. Live circuits must not be broken by separating mated connectors as this may cause arcing, ionisation and burning.

Heat dissipation is greater at maximum resistance in a circuit. Hot spots may occur when resistance is raised locally by damage, e.g. cracked or deformed contacts, broken strands of wire. Local overheating may also result from the use of the incorrect application tools or from poor quality soldering or slack screw terminals. Overheating may occur if the ratings in the product Data Sheet/Catalog are exceeded and can cause breakdown of insulation and hence electric shock.

If heating is allowed to continue it intensifies by further increasing the local resistance through loss of temper of spring contacts, formation of oxide film on contacts and wires and leakage currents through carbonisation of insulation and tracking paths. Fire can then result in the presence of combustible materials and this may release noxious fumes. Overheating may not be visually apparent. Burns may result from touching overheated components.

3 HANDLING

Care must be taken to avoid damage to any component parts of electrical connectors during installation and use. Although there are normally no sharp edges, care must be taken when handling certain components to avoid injury to fingers.

Electrical connectors may be damaged in transit to the customers, and damage may result in creation of hazards. Products should therefore be examined prior to installation/use and rejected if found to be damaged.

4 DISPOSAL

Incineration of certain materials may release noxious or even toxic fumes.

5 APPLICATION

Connectors with exposed contacts should not be selected for use on the current supply side of an electrical circuit, because an electric shock could result from touching exposed contacts on an unmated connector.

Voltages in excess of 30 V ac. or 42.5 V dc are potentially hazardous and care should be taken to ensure that such voltages cannot be transmitted in any way to exposed metal parts of the connector body. The connector and wiring should be checked, before making live, to have no damage to metal parts or insulators, no solder blobs, loose strands, conducting lubricants, swarf, or any other undesired conducting particles. Circuit resistance and continuity check should be made to make certain that there are no high resistance joints or spurious conducting paths. Always use the correct application tools as specified in the Data Sheet/Catalog.

Do not permit untrained personnel to wire, assemble or tamper with connectors. For operation voltage please see appropriate national regulations.

IMPORTANT GENERAL INFORMATION

(i) Air and creepage paths/Operating voltage

The admissible operating voltages depend on the individual applications and the valid national and other applicable safety regulations.

For this reason the air and creepage path data are only reference values. Observe reduction of air and creepage paths due to PC board and/or harnessing.

(ii) Temperature

All information given are temperature limits. The operation temperature depends on the individual application.

(iii) Other important information

ITT Industries continuously endeavours to improve their products. Therefore, ITT Industries products may deviate from the description, technical data and shape as shown in this catalog and data sheets.

(iv) Harnessing and Assembly Instructions

If applicable, our special harnessing and/or assembly instruction has to be adhered to. This is provided on request.

Cannon Worldwide Facilities

Austria:

Afrikanergasse 3
1020 Vienna
FAX: 43.1.2160948 PH: 43.1.2160947

Belgium:

Rue Col. Bourg Str. 105A
1140 Brussels
FAX: 32.2.7269201 PH: 32.2.7267594

China:

No. 24, Block 2
Taohuawu New District
Zhenjiang, Jiangsu 212003
FAX: 86.511.442.8616 PH: 86.511.443.3399

Denmark:

Park Allé 287 A
2605 Brøndby
FAX: 45.43.43.58.58 PH: 45.43.45.52.88

Finland:

Virkatie 1
1510 Vantaa
FAX: 358 9 70039188 PH: 358 9 70039180

France:

2, Ave des Sablons Bouillants,
77109 Meaux Cedex
FAX: 33.1.64.33.16.82 PH: 33.1.60 24 51 51

Germany:

Postfach 11 20
71365 Weinstadt (letters)
Cannonstrasse 1
71384 Weinstadt (parcels)
FAX: 49.7151.699.217 PH: 49.7151.699.0

Hong Kong:

New World Office Building, Room 906
West Wing, 20 Salisbury Road
Tsim Sha Tsui, Kowloon
FAX: 852.2369.5651 PH: 852.2732.2720

Italy:

Via Panzeri 10
20123 Milano
FAX: 39.2.8372036 PH: 39.2.58180.1

Japan:

5362-1, 5-chome, Hibarigaoka,
Zama-shi, Kanagawa 228-0003
FAX: 81.462.57.1680 PH: 81.462.57.2010

Korea:

620 Changkang Bldg.
#22, Dohwa-dong, Mapo-ku
Seoul
FAX: 82.2.717.7330 PH: 82.2.702.7111

The Netherlands

FAX: 31.35.691.8796 PH: 31.35.691.6855

Spain:

Parque Empresarial San Fernando
Edificio Italia 1a planta
28830 Madrid
FAX: 34.91.656.15.83 PH: 34.91.656.03.11

Sweden:

Norr Mälarstrand 64, Jaktvarvet 1,
11235 Stockholm
FAX: 46.8.650.0072 PH: 46.8.650.0071

Switzerland:

Herzogenmühle 18
8304 Wallisellen PH: 41.1.830.3888
FAX: 41.1.830.3104 PH: 41.1.830.3613

United Kingdom:

Jays Close, Viables Estate
Basingstoke, Hants, RG22 4BA
FAX: 44.1256.323356 PH: 44.1256.311200

United States:

666 E. Dyer Road
Santa Ana, CA 92705-5612
FAX: 1.714.628.2142 PH: 1.714.557.4700

Internet:

<http://www.ittcannon.com>

Cannon



ITT Industries

Engineered for life